

# DIMENSIONS GSL2, GSL2.5, GSL3

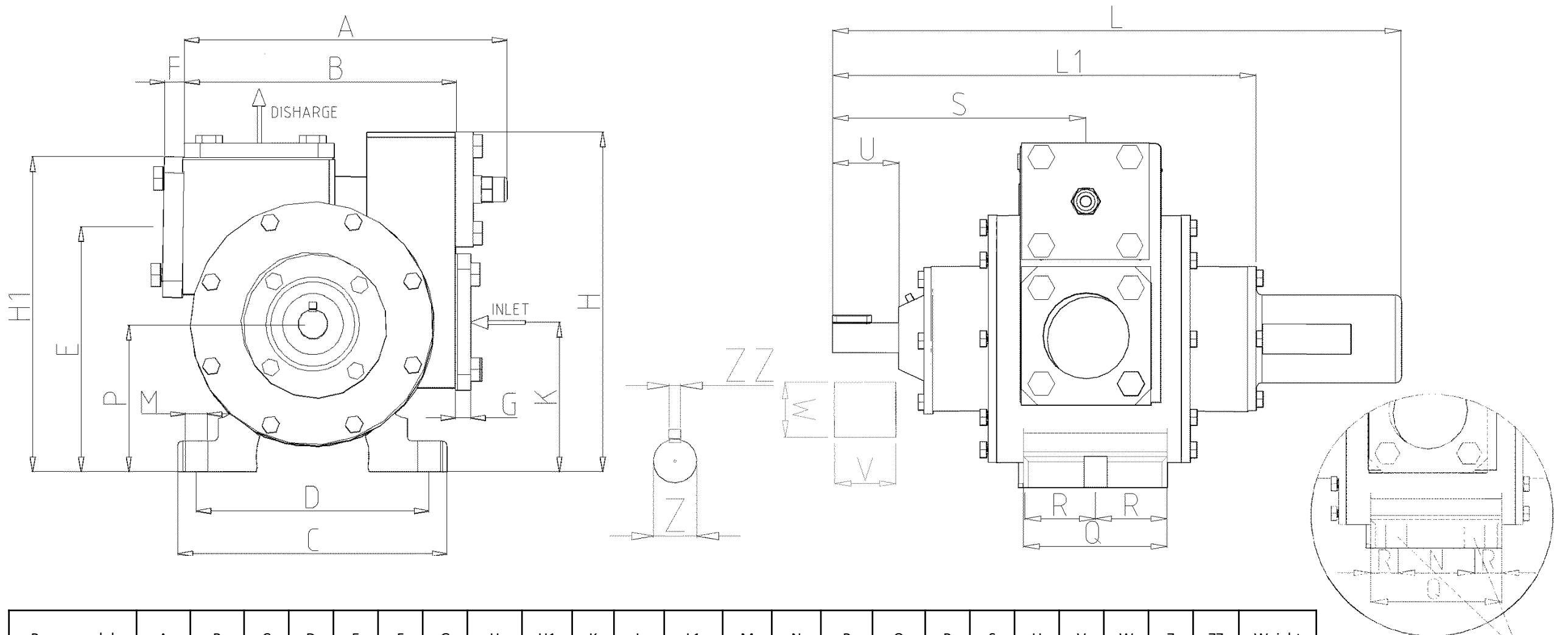

Pump model		A	B	C	D	E	F	G	H	H1	K	L	L1	M	N	P	Q	R	S	U	V	W	Z	ZZ	Weight
GSL2	mm	257	200	195	167	173	16	10	229	221	96	461	381	16	-	104	93	46	223	65	50	48	28	4	36.5kg
	inch	10.11	7.87	7.67	6.57	6.81	0.62	0.39	9.01	8.7	3.78	18.15	15	0.62	-	4.09	3.66	1.81	8.78	2.56	1.97	1.89	1.10	0.15	80lbs
GSL2.5	mm	277	216	208	182	189	16	12	262	248	108	491	409	16	-	110	115	57.5	238	67	50	48	30	4	51.5kg
	inch	10.9	8.5	8.18	7.16	7.44	0.62	0.47	10.31	9.76	4.25	19.33	16.10	0.62	-	4.33	4.52	2.26	9.37	2.63	1.97	1.89	1.18	0.15	112lbs
GSL3	mm	330	266	248	220	-	-	12	328	303	127	524	433	17.5	94	143	130	14	255	75	50	51	35	5	81kg
	inch	12.99	10.47	9.76	8.66	-	-	0.47	12.91	11.93	5	20.63	17.05	0.68	3.7	5.62	5.11	0.55	10	2.95	1.97	2	1.37	0.19	178.5lbs

The GSL3 model has 4holes for mounting

G is the width of the weld flange, for NPT flange the width is 22mm(GSL2-2.5)- 25mm(GSL3) and for BSPP is 35mm(GSL2)- 42(GSL2.5)- 44mm(GSL3)

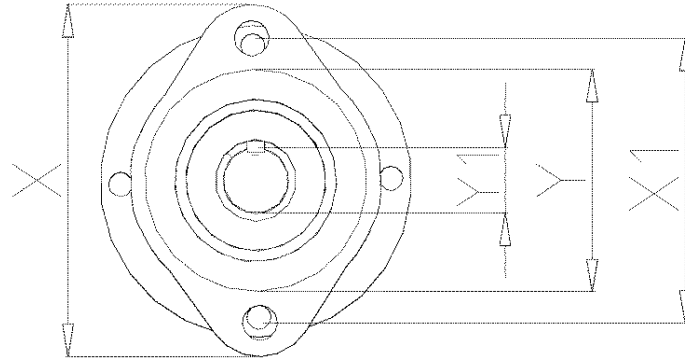
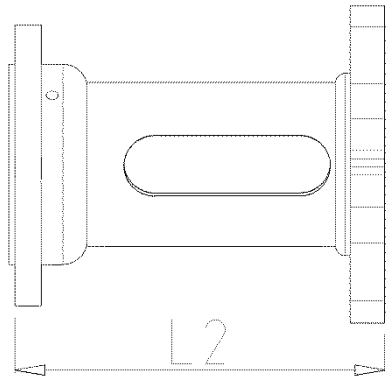

Hydraulic adaptor

In order to measure the total length of the pump + adaptor use the following:  $L1 - (U+26) + L2$   
 In case of double end shaft use  $L - (U+26) + L2$ .

Pump model		L2	X	X1	Y	Y1
GSL2	mm	153	130	106	82.65	25
	inch	6	5.19	4.17	3.25	0.98
GSL2.5	mm	153	130	106	82.65	25
	inch	6	5.19	4.17	3.25	0.98
GSL3	mm	161	130	106	82.65	25
	inch	6.34	5.19	4.17	3.25	0.98

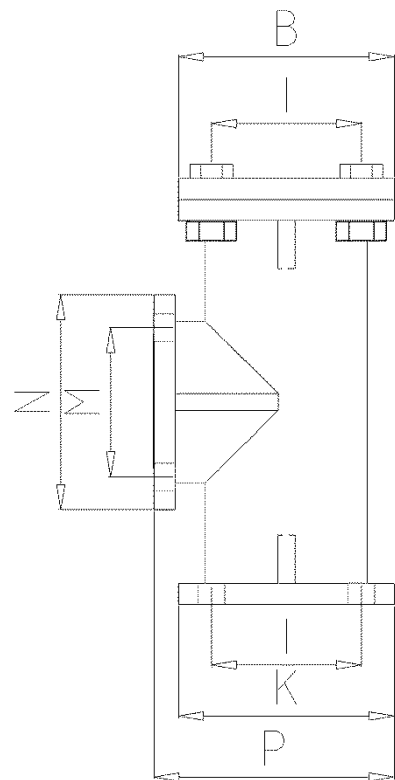
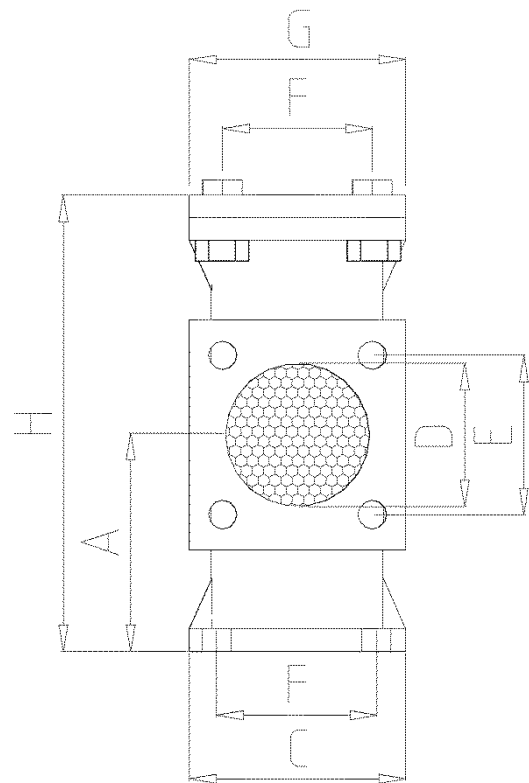

T-filter

Pump model		A	B	C	D	E	F	G	H	I	K	M	N	P
GSL2	mm	89	92	92	52	65	65	92	190	65	92	65	92	111
	inch	3.5	3.62	3.62	2	2.56	2.56	3.62	7.48	2.56	3.62	2.56	3.62	4.37
GSL2.5	mm	101	114	108	63	78	78	108	215	78	114	78	114	133
	inch	3.97	4.49	4.25	2.48	3.07	3.07	4.25	8.46	3.07	4.49	3.07	4.49	5.23
GSL3	mm	104	134	130	82	102	102	130	223	102	134	102	134	146
	inch	4.1	5.27	5.12	3.23	4	4	5.12	8.78	4	5.27	4	5.27	5.75