

**TOTAL  
CONTROL  
SYSTEMS  
TCS**

# 682-15 Piston Meter

*"The Standard of Measurement"*

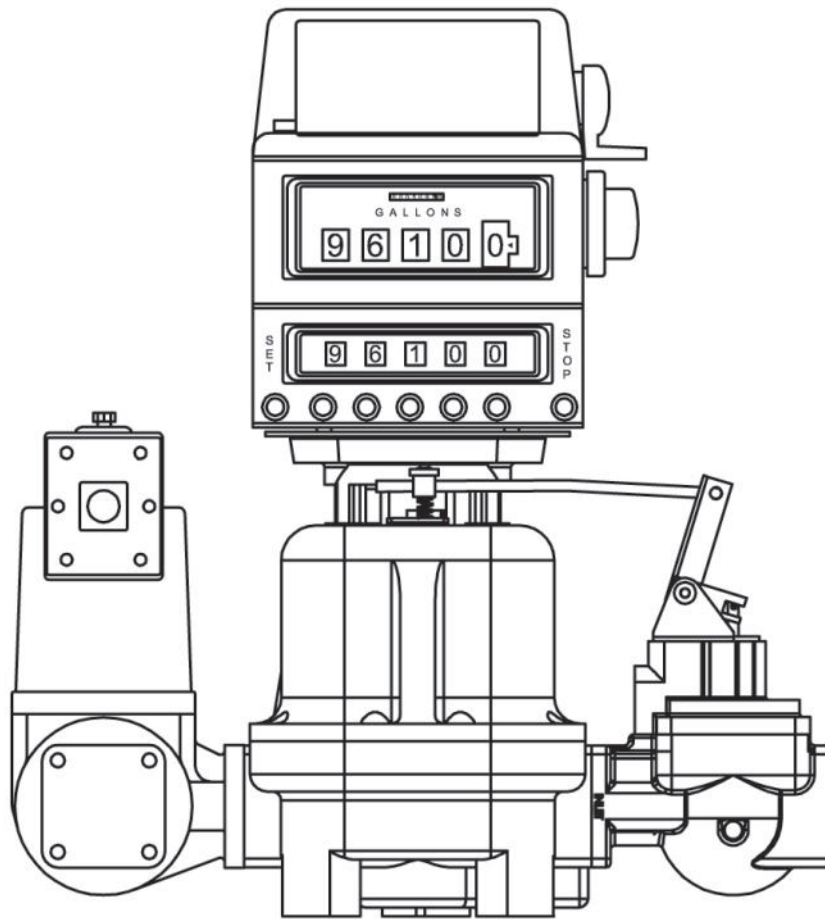

## **Installation, Operation & Maintenance Manual**

## Table of Contents

Safety Warning Symbols	2	Air Eliminator & Strainer Assembly	20
Receipt & Inspection	3	Air Eliminator & Strainer Assembly (Continued)	21
Notice	3	Hydraulic Preset Valve Assembly	22
Meter Overview	4	Hydraulic Preset Valve Assembly (Continued)	23
Meter Specifications	5	Torque Specifications	24
Meter Types	5	Meter Body Repair	25
Material of Construction	6	Meter Bonnet Repair	26
System Recommendations	6	Compensator Shaft Repair	27
System Recommendations (Continued)	7	Drive Shaft Repair	28
System Recommendations (Continued)	8	Plunger Cup Replacement	29
System Recommendations (Continued)	9	Air Eliminator Repair	30
Start Up Recommendations	10	Air Eliminator Repair (Continued)	31
Start Up Recommendations (Continued)	11	Hydraulic Valve	32
Meter Calibration	11	Hydraulic Valve (Continued)	33
Meter Calibration (Continued)	12	Meter Trouble Shooting	34
Meter Calibration (Continued)	13	Air Eliminator Trouble Shooting	35
Calibration Adjustment	14	Hydraulic Preset Valve Trouble Shooting	36
Maintenance	15	Material Safety Data Sheet	37
Maintenance (Continued)	16	MSDS (Continued)	38
Storage Instructions	16	MSDS (Continued)	39
Dimensions	17	MSDS (Continued)	40
Meter Assembly	18	Notes	41
Meter Assembly (Continued)	19	Notes	42
		Warranty	43

## Warning Symbols



### CAUTION

Follow the warning instructions within the following information to avoid equipment failure, personal injury or death.



### TURN POWER OFF

Before performing any maintenance, be sure to turn system power off to avoid any potential electric spark.



### FLAMMABLE

Flammable liquids and their vapors may cause a fire or explosion if ignited.



### EYE PROTECTION

Pressurized systems may cause hazardous leaks and spray that may be dangerous for your eyes. Always wear eye protection around pressurized systems and its hazardous liquids.



### INJURY

Wear gloves for protection from hazardous liquids that may cause irritation or burns.



### READ

Read and understand all related manuals thoroughly. The Engineering and OIM manuals will provide the knowledge for all systems, maintenance and operation procedures. If you have any questions, please consult the factory.

## Receipt & Inspection

Upon receipt of meter shipment, be sure to inspect the packaging and the flow meter assembly for any damage before signing the receipt of the shipment. Notify the delivery company about possible damage and refuse receipt of the shipment.

Meters are individually boxed and are protected with packing material. Each package is identified with the flow meter assembly part number, description, direction of flow and serial number. Verify the meter model is the correct model, size, and configuration as ordered. Contact your distributor if there is any discrepancy or question.

Meter assemblies should be handled with appropriate methods for the awkwardness of size and weight involved. Appropriate clothing and shoes need to be utilized. Transport the meter package to the installation site with appropriate transportation methods, careful not to damage the flow meter.

Be careful of any loose or protruding staples from the packaging, as they can be very sharp and may potentially cause injury.

If foam has been used to protect meter, carefully remove top foam layer before attempting to remove meter assembly from box. Foam packaging maybe formed around the meter assembly making it difficult to remove. If meter is bolted upon a wood pallet remove bolts while being careful not to let the meter tip over when the support has been removed. Do not lift the meter assembly by flex hoses, thermowells, wires, pulsers, or put objects through meter. Removing meter assembly from packaging without adhering these warnings may cause serious injury.

The wooden pallets and bases meet the ISPM 15; Guidelines for Regulating Wood Packaging Material in International Trade through the Timber Products Inspection Company (TP #2134).

Every effort has been made to remove the calibration fluid before shipment. All TCS flow meters are plugged and foam packed flow meters are enclosed in a plastic bag. A Material Safety Data Sheet (MSDS) can be reviewed on PAGE 37. Appropriate precautions should be taken regarding any personal, environmental and material compatibility with the end use system.

## Notice

Total Control Systems (TCS) shall not be liable for technical or editorial errors in this manual or omissions from this manual. TCS makes no warranties, express or implied, including the implied warranties of merchantability and fitness for a particular purpose with respect to this manual and, in no event, shall TCS be liable for special or consequential damages including, but not limited to, loss of production, loss of profits, etc.

The contents of this publication are presented for informational purposes only, and while every effort has been made to ensure their accuracy, they are not to be construed as warranties or guarantees, expressed or implied, regarding the products or services described herein or their use or applicability. We reserve the right to modify or improve the designs or specifications of such products at any time.

TCS does not assume responsibility for the selection, use or maintenance of any product. Responsibility for proper selection, use and maintenance of any TCS product remains solely with the purchaser and end-user.

***All rights reserved. No part of this work may be reproduced or copied in any form or by any means – graphic, electronic or mechanical – without first receiving the written permission of Total Control Systems, Fort Wayne, Indiana USA.***

Flow Meter Identification Plate

	MODEL NUMBER	SERIAL NUMBER	YEAR OF MFG.
	MMQ : 10 Liters	LIQUID TEMP. -10°C to 50°C -14°F to 122°F	METER CAPACITY GPM : 0.50-50 LPM : 10-187
		II 2 G T6 85° C ATEX FILE No.: 07XT304	ACCURACY CLASS 0.5 ENVIRONMENTAL CL. C NTEP CC: 96-100A1 S.W.A No.: 2311 SABS No.: 1130
0518			OIML No.: GB-1274 MID No.: GB-1275 NMI No.: 5/6B/213 "Made in the U.S.A."

## Meter Overview

The 682 meter is a true Positive Displacement Meter, with the inlet and outlet on the same horizontal plain (straight in - straight out). Within the meter, three (3) plungers are fitted within their respective cylindrical measuring chambers. The plungers are joined to a wobble plate, which has a shaft extending from its upper surface. The wobble plate also has a valve pivot attached beneath it. The valve pivot drives a sliding valve from piston to piston as product flows, controlling the sequence of events.

The wobble plate shaft is always held at an inclined position by the center gear post, and the wobble plate itself is prevented from rotating by four guide pins on the pivot bracket assembly.

As product enters the meter, it initially flows into the upper housing. The sliding valve will now be in position to open one measuring cylinder. The plunger for that particular cylinder will be at the upper position. With the pressure below it relieved, and an upper housing full of product, the pressure on top of that plunger will cause it to move toward the bottom of the cylinder, thus forcing out the remaining product. As this occurs, another plunger will be forced from the down position to the upper position. The sliding valve moves via the wobble plate to open the inlet of this cylinder. As the plunger moves upward, it draws product into the measuring cylinder from the bottom. Once this plunger reaches the upper position, and the cycle will repeat, so long as product continues to enter the meter. If product flow stops, pressure in the meter equalizes and motion stops. Thus the meter only operates when product is flowing.

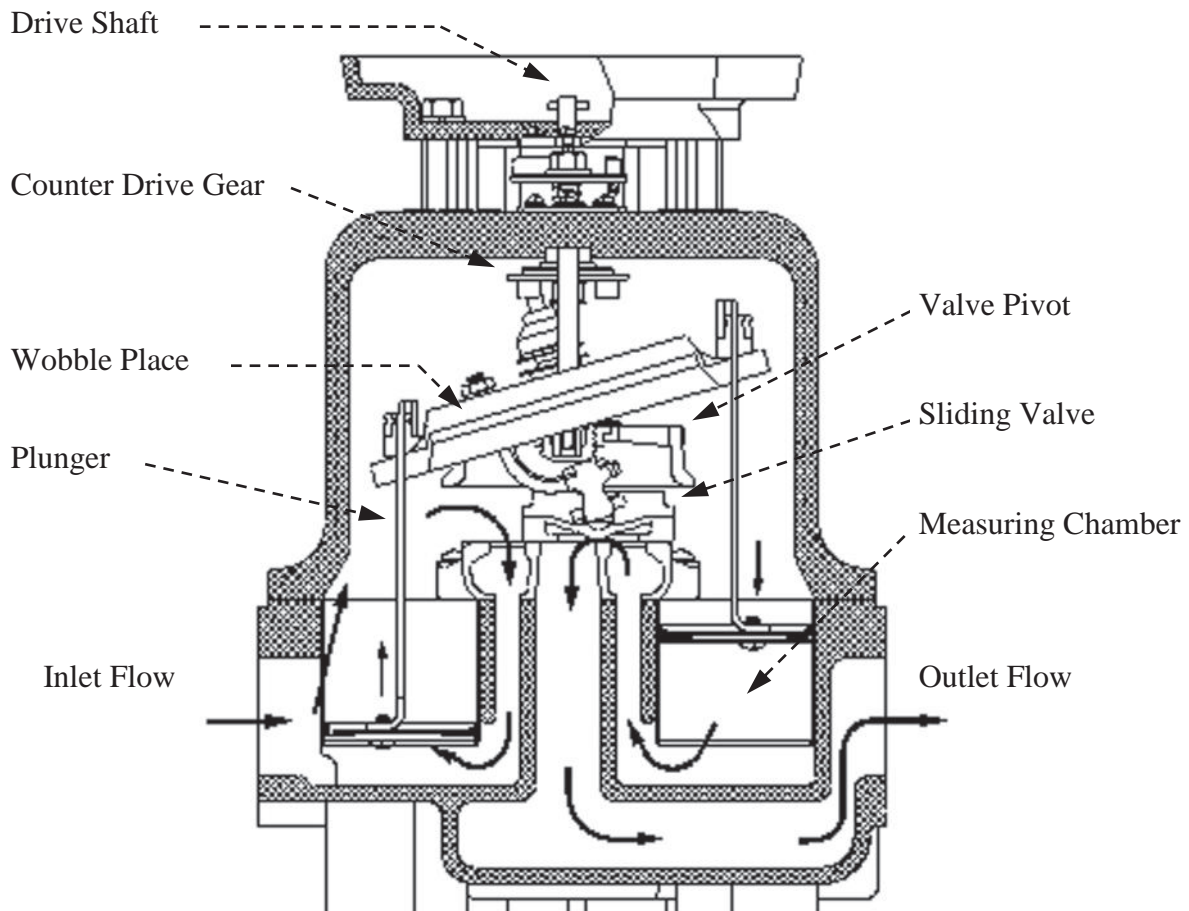

## Meter Specifications

Flange Connection:	1-1/2" NPT Flange Connection, 1" and 2" NPT Flange. Optional BSPT, Slip Weld or ANSI flanges available upon request.
Flow Rate:	0.2 to 50 GPM (0.76 to 189 LPM)
Maximum Pressure:	150 PSI (10.5 BAR)
Working Temperature:	-20 F to 160 F (-28.9 C to 71 C)

## Meter Types

### **SP - Standard Petroleum**

For metering refined petroleum products such as Fuel Oils, Gasoline, Diesel, Bio-Diesel, Motor Oils, Kerosene, Vegetable Oils, Ethylene Glycol, Naptha, etc.

### **SPA - Standard Petroleum (Aviation)**

For metering refined petroleum products such as Aviation Gasoline, Fuel Oils, Jet Fuels, Gasoline, Diesel, Bio-Diesel, Kerosene, etc.

### **SPD - Standard Petroleum (Ductile Iron)**

For metering refined petroleum products such as Leaded and Unleaded Gasoline, Fuel Oils, Diesel, Bio-Diesel, Aviation Gasoline, Ethanol Blends, Methanol Blends, Kerosene, Vegetable Oils, Motor Oils, Ethylene Glycol (Antifreeze), etc.

### **AF - All Ferrous**

For metering Pesticides, Nitrogen Solutions, Fertilizer, Chlorinated Solvents and Paints, Inks, Alcohols, Adhesives, Motor Oils, Molasses, Liquid Feeds, etc.

### **SS - Stainless Steel**

For metering the same liquids as the SP, SPA, SPD and AF flow meters, but includes food processing and special handling fluids such as Nitric, Phosphorus and Glacial Acetic Acids, Anti-Icing Fluids, Vinegar, Fruit Juices, etc.

### **SSD - Stainless Steel (Diesel Exhaust Fluid)**

For metering Diesel Exhaust Fluid (DEF), AdBlue, ARLA and AUS32

## Material of Construction

Description	SP	SPA	SPD	AF	SS	SSD
Housing	Anodized Aluminum	Anodized Aluminum	Ductile Iron	Ductile Iron	Stainless Steel	Stainless Steel
Internal Mechanism	Iron, Steel & Stainless Steel	Ni-Resist II	Iron, Steel & Stainless Steel	Iron, Steel & Stainless Steel	Stainless Steel	Stainless Steel
Ball Bearings	Stainless Steel	Stainless Steel	Stainless Steel	Stainless Steel	Ceramic	Ceramic
Internal Hardware	Stainless Steel	Stainless Steel	Stainless Steel	Stainless Steel	Stainless Steel	Stainless Steel
Packing Seal	FKM	FKM	Simriz®	Simriz®	Simriz®	EPDM
Body O-ring	FKM	FKM	PTFE	PTFE	PTFE	EPDM

Simriz® is a registered trademark of Freudenberg-NOK.

## System Recommendations



### Meter Selection

The flow meter must be carefully chosen from the Meter Selection factors in the Engineering Manual. The meter must be selected based on the operating system and product characteristics. System variables include flow rate, temperature and pressure. The product characteristics include the material compatibility, lubricity, viscosity, suspensions, pH, and whether the product can congeal, crystallize or leave a dry film. Failure to select the correct flow meter may result in system failure or serious injury.

### Air Elimination

In any system that the tank may be completely drained or multiple products manifold into one metering system, the possibility of air being present increases. The solution is an air or vapor eliminator located before the flow meter to vent the air or vapor from the system before it can be measured. Air or vapor elimination is required for all weights and measures regulatory approvals in custody transfer applications.

### Control Valves

Safety and isolation valves should be used throughout the metering system. In any pumping system where there is one (1) pump and multiple flow meters, a digital or hydro-mechanical Rate-of-Flow control valve must be used at each flow meter to prevent over speeding of the flow meters.

## System Recommendations (Continued)



### Best Plumbing Configuration

- 1). Flow meter must have secure mounting to a riser or foundation
- 2). The inlet and outlet piping must be securely supported, in a manner of not to allow pipe stress on flow meter.
- 3). System should be designed to keep the flow meter full of liquid at all times.
- 4). System piping should have full 1-1/2" pipe diameter throughout the metering system to allow for minimal pressure loss.
- 5). The pipe should be laid out as straight as possible to reduce pressure loss from flow restriction.
- 6). The meter and piping must be installed in such a way as to avoid accidental draining of the meter. Meter inlet and outlet should be lower than the associated system plumbing (sump position).
- 7). It is not necessary for the air eliminator to be installed directly bolted to the meter. It can be installed upstream from the meter. For effective operation of the air eliminator, it should be mounted between the meter and any valves, tees or any other potential places where air may enter the system.
- 8). The metering system should include a means for calibration.

### Protection From Debris

On new installations, care must be taken to protect the meter from damage during start-up. It is recommended to put a strainer before the meter. Damage may result from the passage through the meter of dirt, sand, welding slag or spatter, thread cuttings, rust, etc. The insertion of a spool (a flanged length of pipe equal in length to the meter and accessories attached to the meter) in place of the meter until the system is flushed, temporarily bypassing the plumbing around the meter, will also protect the meter from debris. Once the system has run "clean" for a period of time the meter may be reinstalled or protective devices removed.

### Thermal Expansion

As with most liquids, they will expand and contract with temperature. In any system where there is a chance for liquid to be captured between closed valves without relief, thermal expansion will likely occur and create dangerously high pressures within the system. Care should be taken in designing the system in which thermal shock may occur by implementing Pressure Relief Valves or Thermal Expansion Joints in the system design.

When product is trapped within the system, the pressure will increase by 126 PSI (8.69 BAR) for every one (1) temperature degree increase.

# System Recommendations (Continued)



## Viscosity VS. Pressure Loss

The product viscosity will have a direct relationship on the flow rate of the system. The following chart is the flow meter limitation in relation to the flow rate and pressure loss, based on product viscosity. If the system flow rate and viscosity do not meet your requirements, please select a flow meter from our range of 700 series rotary flow meters that have the capability to handle higher flow rates with a lower pressure loss.

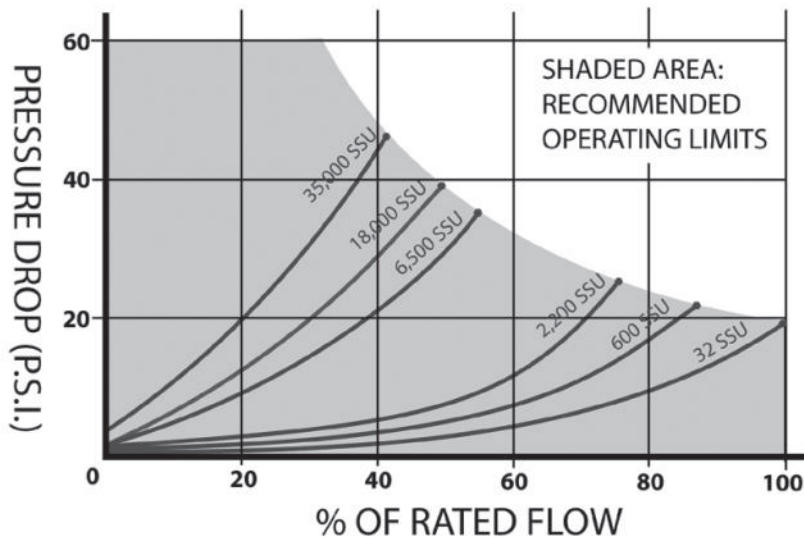

Viscosity Conversion Chart  
(Specific Gravity = 1)

CPS Centipoise	SSU Saybolt Universal	CPS Centipoise	SSU Saybolt Universal	CPS Centipoise	SSU Saybolt Universal	CPS Centipoise	SSU Saybolt Universal
1	31	200	1,000	900	4,300	7,000	32,500
2	34	220	1,100	1,000	4,600	8,000	37,000
4	38	240	1,200	1,200	5,620	8,500	39,500
7	47	260	1,280	1,300	6,100	9,000	41,080
10	60	280	1,380	1,400	6,480	9,500	43,000
15	80	300	1,475	1,500	7,000	10,000	46,500
20	100	320	1,530	1,700	8,000	15,000	69,400
25	130	340	1,630	1,800	8,500	20,000	92,500
30	160	360	1,730	1,900	9,000	30,000	138,500
40	210	380	1,850	2,000	9,400	40,000	185,000
50	260	400	1,950	2,200	10,300	50,000	231,000
60	320	420	2,050	2,400	11,200	60,000	277,500
70	370	440	2,160	2,500	11,600	70,000	323,500
80	430	460	2,270	3,000	14,500	80,000	370,000
90	480	480	2,380	3,500	16,500	90,000	415,500
100	530	500	2,480	4,000	18,500	100,000	462,000
120	580	550	2,660	5,000	23,500	125,000	578,000
140	690	600	2,900	5,500	26,000	150,000	694,000
160	790	700	3,380	6,000	28,000	175,000	810,000
180	900	800	3,880	6,500	30,000	200,000	925,000

$$\text{Centistokes} = \frac{\text{Centipoise}}{\text{Specific Gravity}}$$

$$\text{Centipoise} = \text{Centistokes} \times \text{Specific Gravity}$$



## System Recommendations (Continued)



### Hydraulic Shock (Water Hammer)

Hydraulic shock is a rise in pressure, which happens when an operating system has immediate change in direction of flow such as a fast valve closure at a high operating flow rate. Hydraulic shock can damage any item in the way of the product flow such as internal parts of the meter, valves, and pump. System design and improper operating procedures will elevate this problem. The use of 2-stage preset control valves or surge suppressing bladders or risers will help reduce or eliminate this problem.

To compute the shock pressure when a valve is closed quickly (recommended to be less than 6 PSI):

$$\text{Shock Pressure (PSI)} = 63 \times \text{Velocity (FPS)}$$

In order to eliminate hydraulic shock, you need to slow down the valve closure rate. The time required to close the valve so that the line pressure will not exceed the normal pressure at no flow is:

$$\text{Time (seconds)} = \frac{0.027 \times L \times V}{N - F}$$

- V = Velocity in Feet/Seconds
- L = Length of pipe before the valve in feet
- N = Line pressure at no flow
- F = Line pressure at full flow

### Products that Dry/Congel/Crystallize

There are many liquids that crystallize, harden and/or solidify on contact with air or with an increase in temperature. A proper system design and a good understanding of the product being measured will help to avoid the possibility of air entering into the system and the product being affected.

### Calibration

The meter shall be tested and calibrated with the product it is intended to measure when installed. Total Control Systems shall not be responsible for loss of product or any damages resulting from the end user's failure to test this meter to insure proper calibration. Every 682 series meter is tested and calibrated at the factory to prove it is calibratable in your system. It is the owner's responsibility to report this device to the local Weights and Measures officials for their inspection before the meter is put to use.

## Start up Recommendations



### ***!WARNING!***

Test equipment should be grounded to prevent a possible spark. Test area should have no ignition source. Operators should wear personal protection and prevent any product exposure and environmental issues.

Start-up instruction for new installations or after maintenance and repairs:

- 1). Only properly trained personal should design, install, or operate metering system.
- 2). Remove plastic threaded plugs placed in meter for shipping protection. They are not to be used in meter system because of the PVC plugs low rated pressure, compatibility, and sealing issues.
- 3). Place the meter in an area with ample workspace, secure from vibration, and pipe line stress. Mount and bolt down on to a fixed stand or platform. This prevents meter stress, which will cause leakage and metal fatigue.
- 4). Apply thread sealing compound and gasket materials that are compatible with product.
- 5). Do not weld to meter or accessories. This will weaken housings and cause o-ring and casting leaks.
- 6). Always wear personal safety protection equipment such as goggles, steel toed shoes, gloves and full body clothing.
- 7). Be sure to install a pressure relief valve or expansion joint in the system to protect against thermal expansion.
- 8). Make sure all system components are properly secured and tightened.
- 9). All meter assembly bolts and connections are tight.
- 10). Air eliminator vapor release is properly vented and piped into a reservoir container or back to the supply tank.
- 11). Electrical connections are properly installed and start/stop switches are off and locked-out.
- 12). Flooded suction to the Pump. Fluid is available to system and will not starve or cavitate pump.
- 13). Slow flooding of system

**Start up system with all shut off valves in the closed position.** When a pump is turned on and a valve opened in a new, dry system, tremendous liquid and air pressure can be built up in the piping and forced through the meter. The high pressure and volume of air causes the meter to operate more quickly than normal. When product reaches the meter, there is an abrupt slowing of the meter pistons, which could cause damage to the register, piston arms, plunger cups, main pivot bracket assembly, drive gear and other internal components. *The recommended method of starting any system is to flood the piping gradually. This allows product to slowly force the air from the entire system.*

## Start-Up Recommendations (CONTINUED)



- 14). When operating the meter with accessories, valves should be opened slowly to avoid a pressure surge that can damage the meter or air eliminator. System pressures should be maintained below 70 PSI (4.9 BAR).
- 15). Custody transfer metering systems must be calibrated by a regulatory agency before product can be sold off the meter. Contact your local authorities for proper calibration.
- 16). Strainers should be cleaned frequently or have a maintenance schedule. This will ensure a clean system and long service life.

## Meter Calibration



The method of proving should be selected, and necessary provisions made, during the design stage of the installation. Of the most common used systems, portable provers have the advantage of more closely reproducing the condition under which the product is normally delivered.

### Use Accurate Prover

Scientifically designed provers are commercially available for proving meters, and no other kind should be used. Even scientifically designed provers should be checked periodically for accuracy. Weights and Measures officials have been very cooperative in giving assistance to checking privately owned volumetric provers.

### Recommended size of test measure:

The prover capacity should be equal to at least one minute's flow through the meter at its maximum rate.

These provers are not merely truck compartments or drums, but are scientifically designed test measures, having proper drainage means built into them, a calibration gauge glass neck, and protection against deformation (which causes volume changes).

A "homemade" prover, whether a drum or a tank is not likely to be satisfactory, and may cause expensive errors due to inaccurate meter calibration.

### Setting a Prover

The prover should be set level, using the levels provided on the prover, or separate ones. This insures consistent results when moving the prover from meter to meter.

## Meter Calibration (Continued)



### Where to Test a Meter

The best place to test is in its normal operating position, instead of a test stand. In this way, the correctness of the installation and of the operation conditions will be verified by the test. Always test a meter with the same liquid it is to measure, because a difference in viscosity, temperature and system plumbing slightly affects meter accuracy.

### Discharge Line from Meter

Where a portable prover is used, the liquid is generally discharged in to the prover in the same manner, as a normal delivery would be made. Where a special test connection is used, the discharge line must be arranged to drain to the same point on each test. The meter flow rate and off/on is controlled at the end of the discharge line.

### Wetting the Prover

Reset the meter register to zero, and fill the prover to the zero or 100% marking of the scale. Disregard the meter reading. Drain the prover, and reset the register. The reason for disregarding the first meter reading is that the prover must be wetted, as its calibrated capacity is determined on its wet measure capacity by its manufacturer, and because the prover will be wet for the subsequent tests to be run.

After the prover has drained, allow a definitive time of a few minutes for drainage from the sides of the tank. Total drainage time should be the same between all tests to insure uniform results. If a considerable length of time is to elapse between tests, the wetting operation can be eliminated by allowing the prover to remain full until the next test is to be run.

### Making the Tests

The setup is now ready for accuracy the test. Reset the register to zero, and run the required test through the meter. Do not exceed the maximum recommended rate of flow for the meter. Maximum and minimum recommended rates of flow are marked on the 682 flow meter's identification plate and maintenance manuals.

### Determining Test Results

Run the meter to the mark on the indicator corresponding to the prover capacity, and read the over or under delivery in cubic inches or percent on the calibrated plate on the neck of the prover. If the plate is calibrated in cubic inches, the percentage error can readily be computed on the following basis:

- (a) One gallon equals 231 cu.in.
- (b) A 100-gallon prover holds 23,100 cu.in. Therefore, 23.1 cu.in. represents 0.1% error.

## Meter Calibration (Continued)



The National Institute of Standards and Technology, in its NIST Handbook 44 specifies a tolerance of plus or minus the following:

Indication of Device	Tolerance		
	Acceptance Test	Maintenance Test	Special Test
Wholesale	0.2%	0.3%	0.5%
Vehicle	0.15%	0.3%	0.45%

### METER TOLERANCE

Acceptance tolerances apply to new meters and repaired meters after reconditioning.

#### Repeatability

When multiple tests are conducted at approximately the same flow rate and draft size, the range of test results for the flow rate shall not exceed 40% of the absolute value of the maintenance/normal tolerance and the results of each test shall be within the applicable tolerance.

#### Changing Meter Calibration

Refer to meter literature for method of changing meter calibration. Any change in the meter calibration adjustment will change the delivery in the same amount for all rates of flow. That is, the calibration curve retains its shape, but is moved up or down. Therefore, if a meter tests satisfactorily at full flow, but drops off too much at low flow, changing the calibration will not remedy this condition; it will bring the low flow test to 100%, but it will also bring the full flow above 100% by the same amount that the low flow was raised. A condition of this kind is caused either by the metering system, need for meter cleaning or repairs, or because of an attempt to retain accuracy below the minimum recommended rate of flow for the meter.

#### Temperature Correction

If the conditions of testing are such that there will be a change of more than a few degrees in the temperature of the liquids between the time it passes through the meter and the time the prover is read, it will be advisable to make a temperature correction to the prover readings. To do this, it is necessary to install thermowells; to take readings of the temperature of the liquids in the meter and in the prover; and to take the degrees API of the liquid. Corrections can then be easily made by the use of the National Standard API Tables.

## Calibration Adjustment

- A. It is important to test the repeatability and accuracy of your meter. To test repeatability:
- 1) Run a fast (high gallons per minute) test in your prover and record how much the meter is over or under registering. Do NOT change the meter's calibration.
  - 2) Run a slow (low gallons per minute) test and again record how much the meter is over or under registration.

If the results from the fast and the slow test are the same or close to the same, the meter can be successfully calibrated. If the test results differ beyond the rated tolerance of the meter, then repairs are necessary before the meter can be calibrated.

- B. A valve or nozzle must be at the end of the delivery hose (at the prover).  
C. Turn on the pump and purge the system of air. Leave the pump on.  
D. Shut off the valve at the end of the delivery hose and let the system pressurize.  
E. Wet the prover and empty it, letting it drip for 30 seconds.  
F. Reset the register on the meter to "0".  
G. Fill the prover to the line marked "0".  
H. Record what the register reads. Every  $1/10$  gallon difference between the register and the 5 gallons known to be in the prover equals a  $\pm 2\%$  inaccuracy. For example, a reading of 4.9 gallons on the register, compared with a 5 gallon prover filled to the "0" line means the meter is giving away 2% of the product it meters.  
I. The top disc on the calibrator has a tab sticking up. The tab is marked with a "plus" and a "minus" sign. This indicates "plus" product and "minus" product. By turning the disc in one direction or the other, product delivery will be increased or decreased.  
J. A full revolution of the disc will change the calibration of the meter 3%. Therefore, if the meter shows 4.9 gallons on the register, the disc should be turned  $2/3$  of one revolution (2%) in the minus direction, since in this case we want less product through the meter (5 gallons passed through it in the test, and only registered 4.9 gallons).  
K. Empty the prover and let it drip for 30 seconds.  
L. Run a second test and make a fine adjustment; and then another test to check your fine adjustment.  
M. Replace the pin into the disc, and seal it with the seal wire.

NOTE: If your meter has a mechanical or electronic preset, it should be set high enough so that it doesn't affect the calibration process. Only a valve at the prover should be used to control the flow during calibration.

## Maintenance



### ***!WARNING!***

Test equipment should be grounded to prevent a possible spark. Test area should have no ignition source. Operators should wear personal protection and prevent any product exposure and environmental issues.

- 1). Keeping accurate maintenance and calibration records can be an excellent tool in determining the frequency of inspection or maintenance for a system. As the meter wears, the calibration will be affected and require adjustment. A personality profile can be created for each meter to help guide in a maintenance schedule.
- 2). Great care should be utilized in the maintenance of the metering system. Personal safety protection, environmental hazards, and government regulations need to be the foremost priority. Only fully trained personnel should be involved in maintenance. Failure to use original TCS replacement parts will void any Weights & Measures approvals and risk damage to the meter system.
- 3). ALWAYS RELIEVE INTERNAL SYSTEM PRESSURE TO ZERO BEFORE DISASSEMBLY OR INSPECTION.
- 4). SERIOUS INJURY OR DEATH FROM FIRE OR EXPLOSION COULD RESULT FROM MAINTENANCE OF AN IMPROPERLY DEPRESSURIZED AND EVACUATED SYSTEM.
- 5). Total Control Systems flow meters and accessories are often used with petroleum, solvents, chemicals, and other liquids that may be explosive, extremely flammable, very toxic, oxidizing, and corrosive. Severe injury or fatalities may arise if appropriate safety precautions are not followed.
- 6). Before replacing or cleaning filter/strainer screen, the electrical system must be turned off. Product needs to be drained from system. Collect all product and return to storage or dispose of properly. Replace all drain plugs that were removed. Personal safety protection must be worn at this time. Make sure there is adequate ventilation in the area. The metering system will not completely drain so make sure you collect extra product when you remove the strainer cover. Clean the screen once a week, or more often if there is a lot of sediment in the system. Make sure there is no ignition source and the system is grounded. Replace all plugs that were removed for drainage.
- 7). The metering system is heavy and awkward so take precaution to handle it properly.
- 8). When inspecting the spring loaded preset valves do not place anything inside the housing, as the action of the valve will pinch this object when the valve closes.

## Maintenance (CONTINUED)



### ***!WARNING!***

Test equipment should be grounded to prevent a possible spark. Test area should have no ignition source. Operators should wear personal protection and prevent any product exposure and environmental issues.

- 9). When removing gaskets or o-rings, carefully check for damage or corrosion. Any cracked, rough, worn, elongated or swollen o-rings need to be replaced. When replacing the o-rings, place grease along the inside of the o-ring groove or completely around the o-ring to help the o-ring stay in the o-ring groove during assembly. If o-ring is pinched or not in the o-ring groove, the meter system will leak and cause serious problems to the environment and equipment. Collect all replaced parts and dispose of properly. Do not weld any part of the meter system or accessories as this will weaken the part and allow for leaks
- 10). All bolts and screws need to be coated with Anti-Seize lubricant. Then follow the torque specifications for each flow meter, air eliminator, strainer or preset valve bolt on page 24.
- 11). Recommended levels of maintenance and inspection will depend upon the system variables, such as the products being measured, their corrosiveness, system pressure requirements, government or company regulations, and age of metering system. If hydrostatic testing is required, the system pressure should not exceed 1.5 times the marked meter pressure. It is not recommended to pneumatically test the meter system at anytime.
- 12). If any component of the meter system is removed from the system, it should be thoroughly flushed with a compatible liquid. After this is done, immediately refill the meter or accessory with a compatible liquid to prevent corrosion and water build up.

## Storage Instructions



Short periods of non-use of the meter (a week or less) should present no problem, provided that the meter remains full of product. For long periods of non-use, such as winter storage, the following procedure is recommended. Before long-term storage, a good practice is calibration of the meter to determine that it is functioning properly.

- 1). To store the meter when it is left in line, flush the system with clean water until 70-80 gallons of water have gone through the meter.
- 2). Pump a 50% anti-freeze / 50% water solution through the entire system (100% RV antifreeze may be used instead). With the pump running, shut off a valve downstream from the meter, making sure that anti-freeze solution is present at that point. Then close an upstream valve, such that the meter remains full of anti-freeze solution.
- 3). Remove the register from the meter, and lubricate the drive coupling shaft. After lubrication, reassemble the register onto the meter.

When starting the system after a period of storage, check the meter's calibration as detailed earlier in the service manual.



# 682-15 Dimensions

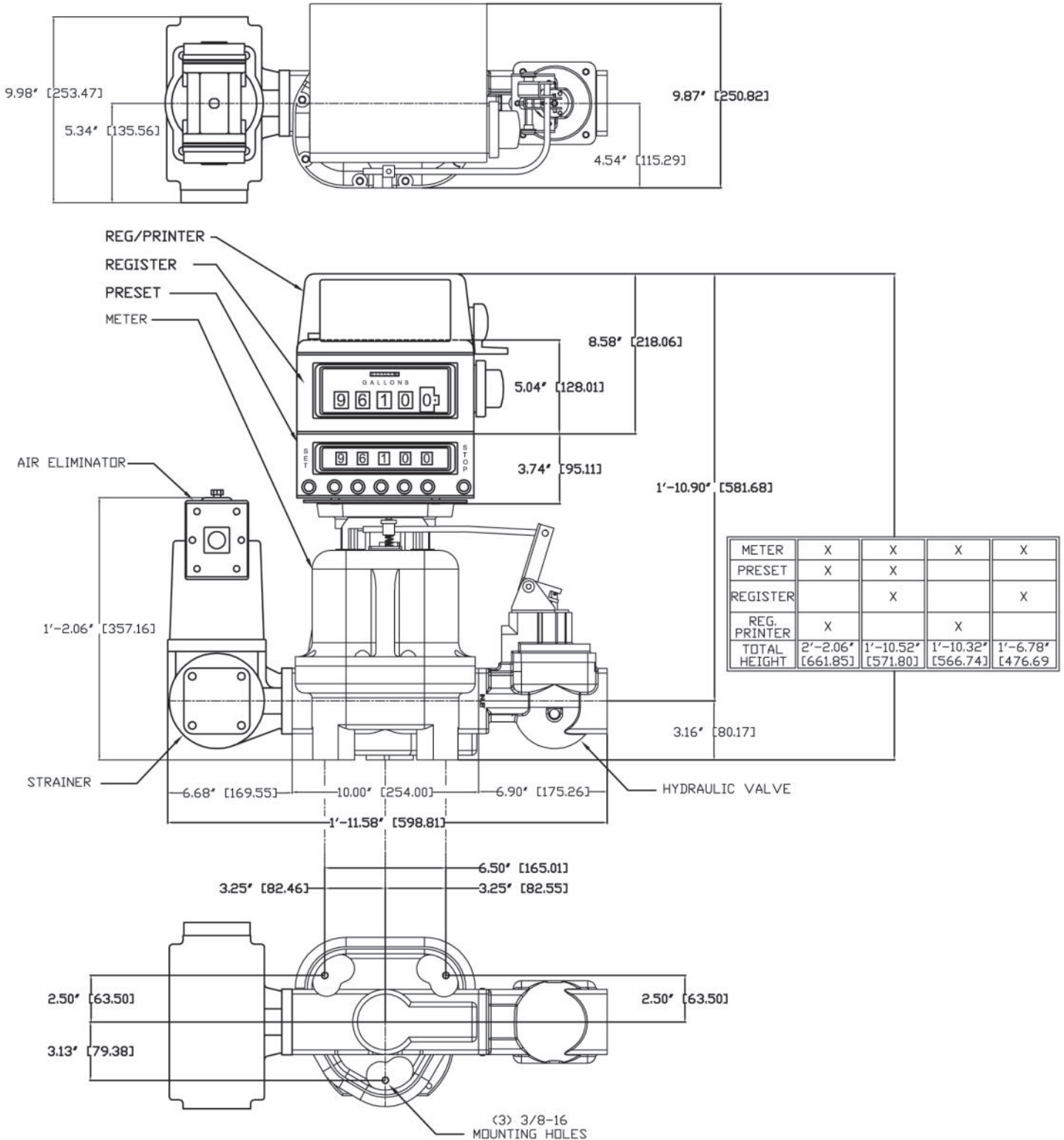

All measurements are in inches (millimeters)

# 682-15 Meter Assembly

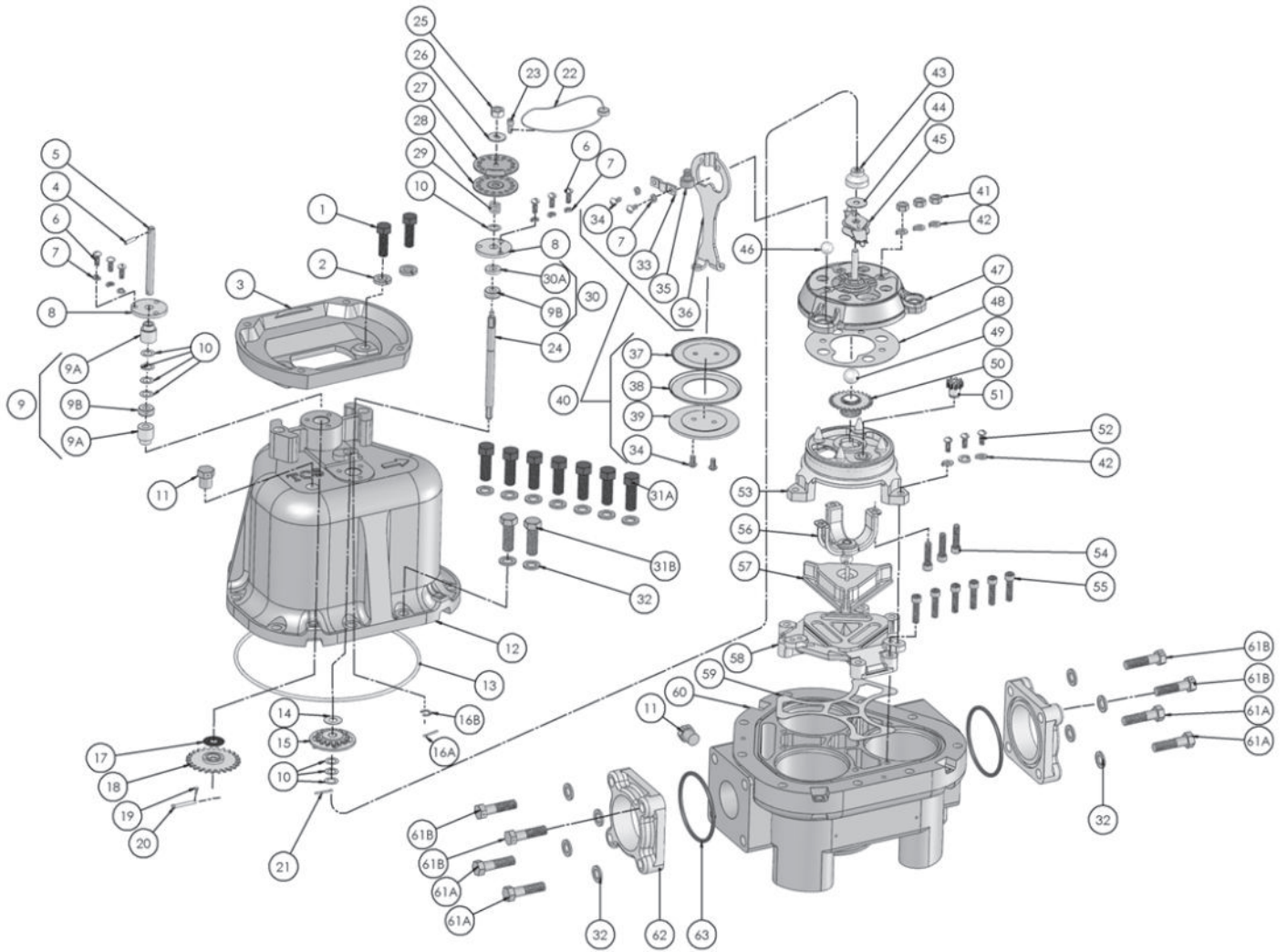

# 682-15 Meter Assembly

Item	Description	Qty	SP	SPA	SPD	AF	SS	SSD
1	Screw, 3/8-16 x 1-1/8	2	297-050361	297-050361	297-050361	297-050361	1-126333	1-126333
2	Washer, 3/8 Split Lock	2	15-050641	15-050641	15-050641	15-050641	1-126334	1-126334
3	Counter Support	1	680050	680050	1-312518	1-312518	1-312518	680050
4	Roll Pin	1	3-130752	3-130752	3-130752	3-130752	3-130752	3-130752
5	Drive Shaft	1	1-126900	1-126900	1-126900	1-126900	1-126900	1-126900
6	Screw, 10-24 x 1/2	6	1-128279	1-128279	1-128279	1-128279	1-128279	1-128279
7	Washer, #10 Split Lock	12	1-126316	1-126316	1-126316	1-126316	1-126316	1-126316
8	Compression Washer	2	1-130872	1-130872	1-130872	1-130872	2-130872	2-130872
9	Drive Shaft Packing Kit	1	226199-1	226199-1	226199-1	226199-1	226199-1	680699-2
10	Washer, 9/16 OD x 0.10 T	5	1-126903	1-126903	1-126903	1-126903	1-126903	1-126903
11	Pipe Plug, 1/4"	2	1-126146	1-126146	1-126146	1-126146	2-126146	2-126146
12	Cover & Post Assembly	1	680250	680250	680253	680253	680252	P680155
13	O-Ring	1	680210	680210	680212	680212	680212	680810
14	Washer, 3/4 OD x 0.015 Rulon	1	1-125120	1-125120	1-125120	1-125120	1-125120	1-125120
15	Counter Drive Gear Assembly	1	226136-1	226136-1	226136-1	226136-1	226136-2	226136-1
16A	Cotter Pin, 1/16 x 1/2	2	-	-	-	-	1-126318	1-126318
16B	Retaining Ring, 0.320 ID x 0.025 T	1	12-053420	12-053420	12-053420	12-053420	-	-
17	Washer, 7/8 OD x 0.15 Rulon	1	1-125407	1-125407	1-125407	1-125407	1-125407	1-125407
18	Drive Shaft Gear	1	226135-1	226135-1	226135-1	226135-1	226135-2	226135-1
19	Cotter Pin, 3/16 x 1-1/4	1	13-052870	13-052870	13-052870	13-052870	1-126319	13-052870
20	Drive Shaft Pin 1/4 x 1-3/32	1	1-126913	1-126913	1-126913	1-126913	1-126914	1-126913
21	Cotter Pin, 1/16 x 1/2	1	1-126318	1-126318	1-126318	1-126318	1-126318	1-126318
22	Seal Wire and Seal	1	1-118849	1-118849	1-118849	1-118849	1-118849	1-118849
23	Seal Pin	1	1-019602	1-019602	1-019602	1-019602	1-126929	1-126929
24	Compensator Shaft	1	1-224081	1-224081	1-224081	1-224081	1-224119	1-224119
25	Nut, 5/15-18	1	2-050301	2-050301	2-050301	2-050301	1-126320	1-126320
26	Compensating Washer	1	1-126927	1-126927	1-126927	1-126927	1-126927	1-126927
27	Index Disc	1	1-126931	1-126931	1-126931	2-126931	1-126931	1-126931
28	Index Plate	1	1-226085	1-226085	1-226085	1-226085	1-130853	1-130853
29	Compression Spring	1	1-130935	1-130935	1-130935	1-130935	1-130935	1-130935
30	Compensator Shaft Seal Kit	1	227000-1	227000-1	227000-1	227000-1	227000-1	680700-2
31A	Screw, 7/16-14 x 1-1/4	7	600054	600054	700054	700054	700054	700054
31B	Drilled Screw, 7/16-14 x 1-1/4	2	600054D	600054D	700054D	700054D	700054D	700054D
32	Flange Washers	1	702018	702018	702018	702018	702018	702018
33	Bearing Retainer, Plunger	3	1-126957	1-126957	1-126957	1-126957	1-126957	1-126957
34	Plunger Screw, 10-32 x 3/8	12	1-126329	1-126329	1-126329	1-126329	1-126329	1-126329
35	Bearing Seat, Plunger	3	1-219378	1-219378	1-219378	1-219378	1-130908	1-130908
36	Piston Connector, Plunger	3	1-126939	1-126939	1-126939	1-126939	1-126939	P1-126939
37	Plunger Disc	3	1-126878	1-126878	1-126878	1-126878	1-126878	P1-126878
38	Plunger Cup Kit (3 Cups)	1	218769-1	218769-1	218769-1	218769-1	218769-1	218769-1
39	Plunger Cup Support	3	1-126876	1-126876	1-126876	1-126876	1-126876	P1-126876
40	Plunger Assembly	3	226182-9	226182-2	226182-9	226182-2	226182-2	219407-6
41	Nut, 1/4-20	3	1-126321	1-126321	1-126321	1-126321	1-126321	1-126321
42	Washer, 1/4 Split Lock	6	1-126317	1-126317	1-126317	1-126317	1-126317	1-126317
43	Slack Roller Assembly	1	219800-1	219800-1	219800-1	219800-1	219800-2	680051
44	Washer, 0.863 OD x 0.030 Rulon	1	1-125103	1-125103	1-125103	1-125103	1-125104	1-125104
45	Slack Spring Assembly	1	898 221403-1	221403-2	898 221403-1	221403-2	221403-5	221403-5
46	Ball, 1/4 Dia.	3	1-124588	1-124588	1-124588	1-124588	2-130905	2-130905
47	Wobble Plate Assembly	1	219331-1	219331-2	219331-1	219331-1	219901-2	219901P
48	Wear Plate	1	1-217934	1-217934	1-217934	1-217934	-	-
49	Ball, 5/8 Dia.	1	1-125046	1-125046	1-125046	1-125046	1-130905	1-130905
50	Main Pivot Assembly	1	219572-4	219572-4	219572-4	219572-4	219572-4	219572-4
51	Compensating Pinion	1	1-129607	1-129607	1-129607	1-129607	2-129607	1-129607
52	Screw, 1/4-20 x 3/4	3	1-126327	1-126327	1-126327	1-126327	1-126327	1-126327
53	Main Pivot Bracket Assembly	1	218236-4	218236-2	218236-4	218236-4	219260-6	219260P
54	Slotted Screw, 1/4-20 x 1	3	1-126962	1-126962	1-126962	1-126962	1-126962	1-126962
55	Screw, 1/4-20 x 1	6	1-126326	1-126326	1-126326	1-126326	1-126326	1-126326
56	Bracket	1	3-218608	3-218608	3-218608	3-218608	6-218608	P6-218608
57	Valve	1	1-219330	1-219330	1-219330	1-219330	220496-2	220496-2
58	Seat	1	1-038618	1-038622	1-038618	1-038618	1-310336	P310336
59	Seat Gasket	1	-	-	-	1-038619	1-038619	1-038619
60	Body, Seat, and Pin Assembly	1	680125	680122	680124	680126	680118	680128P
61A	Flange Bolts	4	702017	702017	702017	702017	702017	702037
61B	Drilled Flange Bolts	4	702017D	702017D	702017D	702017D	702017D	702037D
62A	Flange; 1-1/2" NPT	2	701600	701600	701601	701601	701602	P701602
62B	Flange; 1-1/2" BSPT	2	701603	701603	701621	701621	701812	P701812
63	Flange O-ring	2	702012	702012	702013	702013	702013	702812



## 740-20 Air Eliminator / Strainer Assembly

Item	Description	Qty	740-20					
			SP	SPD	IP	AF	SS	SSD
1A	Cap Screw	8	740050	740050	740050	740050	740050	740050
1B	Drilled Cap Screw	4	740050D	740050D	740050D	740050D	740050D	740050D
2	Ring Washer	12	740051	740051	740051	740051	740051	740051
3A	Outlet Cover; 1" NPT	2	740010	740016	740010	740016	740018	P740018
3B	Outlet Cover; 1" BSPT	2	740710	740716	740710	740716	740718	P740718
4	Encapsulated Valve Plate	2	740205	740215	740215	740215	740215	740205
5	Screw	4	740030	740030	740030	740030	740030	740030
6	Split Lock Washer	2	740017	740017	740017	740017	740017	740017
7A	Cap Screw	2	700054	700054	700054	700054	700054	700054
7B	Drilled Cap Screw	2	700054D	700054D	700054D	700054D	700054D	700054D
8	Flat Washer	4	702018	702018	702018	702018	702018	702018
9	Air Eliminator Housing	1	740020	740022	740020	740022	740024	P740024
10	Plug	1	2-126146	2-126146	2-126146	2-126146	2-126146	2-126146
11	Retaining Clip	2	740012	740012	740012	740012	740012	740012
12	PTFE Reed Strip	2	-	740077	740077	740077	740077	740077
13	Float Assembly	1	740013	740013	740013	740013	740013	740013
14	Diffuser and Shaft Assembly	1	740035	740035	740035	740035	740035	740035
15	Top Seal O-ring	1	740009	740019	740019	740019	740019	740809
16	Strainer Housing	1	742021	742022	742021	742022	742023	P742023
17A	0.050 Strainer Basket, STD	1	-	-	742005	742005	742005	-
17B	40M Strainer Basket, STD	1	742010	742010	-	-	-	P742010
17C	80M Strainer Basket	1	742015	742015	-	-	-	-
17D	100M Strainer Basket	1	742025	742025	-	-	-	-
18	Seal Ring	1	742003	42004	742004	742004	742004	742803
19	Basket Cover	1	742050	742052	742050	742052	742053	P742053
20	Basket Cover; Two 1/2" NPT Ports	1	742055	742056	742055	742056	742057	-
21	3/8" x 1/2" NPT Thermowell	1	740305	740405	740305	740405	740405	-
22	Strainer Cover, Optional	1	740041	740042	740041	740042	740042	-
23	Reed Valve	2	740007	740007	740007	740007	740007	740007
24	Plate Seal	4	740005	740004	740004	740004	740004	-
25	Valve Plate	2	740038	740006	740006	740006	740006	-
26	Valve Plate Kit	2	740138	740106	740106	740106	740106	-
27	1/2" x 1/2" NPT Thermowell	1	740300	740400	740300	740400	740400	-
28	Flange O-ring	1	702012	702013	702012	702013	702013	702812
29	Basket Cover; One 1/2" NPT Port	1	742155	742156	742155	742156	742157	-

# 650-15 Hydraulic Preset Valve Assembly

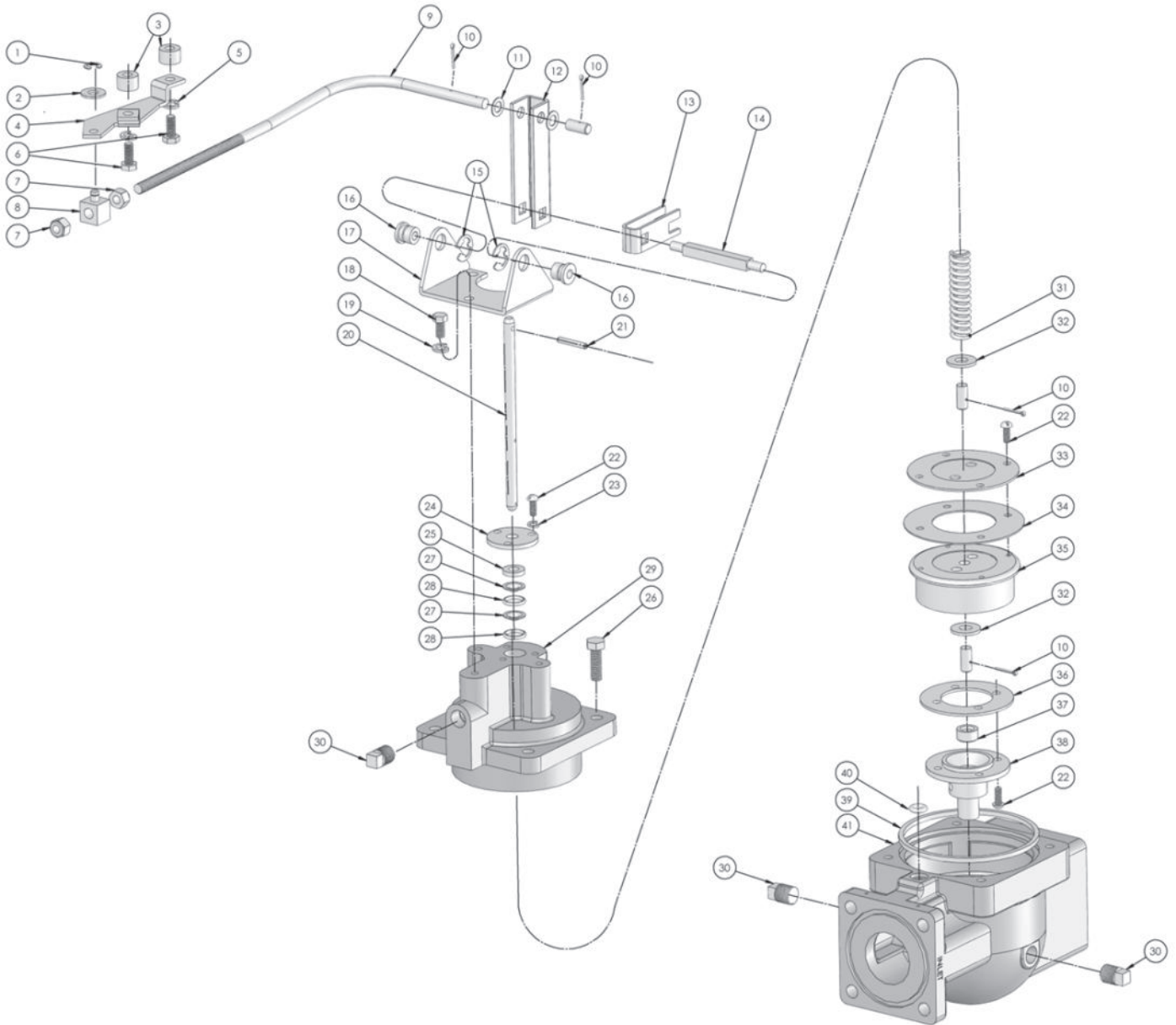

## 650-15 Hydraulic Preset Valve Assembly

Item	Description	Qty	SP	AF	SS	SSD
1	Retaining Ring	1	6-052482	6-052482	6-052482	6-052482
2	Washer, Flat	1	65034	65034	65034	65034
3	Spacer	2	1-130852	1-130852	1-130852	1-130852
4	Preset Bracket	1	1-226102	1-226102	1-226102	1-226102
5	Washer, Split Lock	2	ZPW 1/4LW	ZPW 1/4LW	ZPW 1/4LW	ZPW 1/4LW
6	Screw	2	68004	68004	68004	68004
7	Locknut	2	65008	65008	65008	65008
8	Swivel Block	1	1-128140	1-128140	1-128140	1-128140
9	Connecting Link	1	65025	65025	65025	65025
10	Cotter Pin	4	1-126318	1-126318	1-126318	1-126318
11	Washer	2	1-126903	1-126903	1-126903	1-126903
12	Actuating Arm	1	65016	65016	65016	65016
13	Lifter	1	65010	65010	65010	65010
14	Valve Handle Shaft	1	65005	65005	65005	65005
15	Retaining Ring	2	65026	65026	65026	65026
16	Shaft Bearing	2	65004	65004	65004	65004
17	Bracket	1	65012	65012	65012	65012
18	Screw, 1/4-20 x 1/2	3	65032	65032	65032	65032
19	Washer, Split Lock	3	1-126317	1-126317	1-126317	1-126317
20	Valve Stem	1	65018	65018	65018	65018
21	Roll Pin, 5/32 x 1	1	65027	65027	65027	65027
22	Screw, 10-24 x 1/2	11	1-128279	1-128279	1-128279	1-128279
23	Washer	3	1-126316	1-126316	1-126316	1-126316
24	Compression Washer	1	1-130872	1-130872	1-130872	1-130872
25	Spacer	1	1-130893	1-130893	1-130893	1-130893
26A	Screw, 5/16-18 x 1	2	65033	65033	65033	65033
26B	Drilled Screw, 5/16-18 x 1	2	65033D	65033D	65033D	65033D
27	Seal	2	2-126898	2-126898	2-126898	2-126898
28	Seal O-Ring	2	5-311554	5-311554	5-311554	650803
29	Cover	1	650015	65031-2	65031-4	P65031-4
30	Pipe Plug	3	2-051913	2-051913	2-126146	2-126146
31	Poppet Spring	1	65007	65007	65007	65007
32	Washer, Flat	2	65035	65035	65035	65035
33	Plunger Cup Support	1	65014	65014	65014	65014
34	Plunger Cup	1	65013	65013	65013	65013
35	Plunger	1	65030	65030	65030	65030
36	Valve Disc	1	65009	65009	65009	65019
37	Valve Seat	1	65006	65006	65006	65006
38	Poppet Guide	1	65029	65029	65029	65029
39	Gasket	1	65021	65021	65021	65022
40	O-Ring	1	65001	65001	65001	65002
41	Valve Body Assembly	1	650127	650227	650327	P650427

## TORQUE SPECIFICATIONS

### 682-15 METER ASSEMBLY

Part Number	Tool	Bolt/Nut Size	Foot Lbs.		Newton Meter	
			Unlubricated	Lubricated	Unlubricated	Lubricated
TCS 3-23095	5/8" hex wrench/socket	7/16-14 UNC	50	37.5	67.8	50
TCS 1-130876	5/8" hex wrench/socket	7/16-14 UNC	27	20	36.6	27
TCS 297-050361	9/16" hex wrench/socket	3/8-16 UNC	30	22.5	40.6	30
TCS 1-126353	9/16" hex wrench/socket	3/8-16 UNC	19.7	11.8	26.7	16
TCS 1-128279	slotted screwdriver	10-24 UNC	1.9	1.1	2.6	1.5
TCS5-230958	3/4" hex wrench/socket	1/2-13 UNC	43.1	25.9	58.4	35.1
TCS 1-126329	slotted screwdriver	10-32 UNF	1.9	1.1	2.6	1.5
TCS 1-126321	7/16" hex wrench/socket	1/4-20 NUT	6.3	3.8	8.5	5.2
TCS 1-126327	slotted screwdriver	1/4-20 UNC	6.3	3.8	8.5	5.2
TCS 1-126326	7/16" hex wrench/socket	1/4-20 UNC	6.3	3.8	8.5	5.2

### 650-15 HYDRAULIC PRESET VALVE ASSEMBLY

Part Number	Tool	Bolt/Nut Size	Foot Lbs.		Newton Meter	
			Unlubricated	Lubricated	Unlubricated	Lubricated
TCS 65033	1/2" hex wrench/socket	5/16-18 UNC	11	6.6	14.9	8.9
TCS 65032	7/16" hex wrench/socket	1/4-20 UNC	6.3	3.8	8.5	5.2
TCS 1-126279	slotted screwdriver	10-24 UNC	1.9	1.1	2.6	1.5

### 740-20 AIR ELIMINATOR/STRAINER ASSEMBLY

Part Number	Tool	Bolt/Nut Size	Foot Lbs.		Newton Meter	
			Unlubricated	Lubricated	Unlubricated	Lubricated
TCS 740050	1/2" hex screw wrench/socket	5/16-18 UNC 2B	11	6.6	14.9	8.9
TCS 701017	9/16" hex screw wrench/socket	3/8-16 UNC 2B	19.7	11.8	26.7	16.0
TCS 740030	slotted screwdriver	8-32 UNC 2B	1.65	1.0	2.2	1.4



## 682 METER BODY REPAIR INSTRUCTIONS



### ***!WARNING!***

All internal pressure must be relieved to ZERO (0) pressure before beginning disassembly of meter or components

- I. A. Remove all parts and seals from the meter body and clean them. You may air blast parts with a **glass bead** material to clean parts.
- B. Always replace bracket (#56), screws (#54) & (#34), plunger cups (#38) and Rulon seals (#14, 17 & 44).
- C. Check for:
  1. Excessive wear on the wobble plate (#47) guide holes.
  2. Pitting on ball bearings (#49) & (#46).
  3. Excessive wear on the guide posts on main pivot bracket assembly (#53).
  4. Wear on the SP/SPA/SPD/AF valve (#57) or SS/SSD valve insert (#57).
  5. Wear on the valve seat (#58).
  6. Wrinkles on the sleeves in cylinders of the body.  
NOTE: Honing sleeves with Emory wheel may buff out wrinkles.
- II. A. Mount valve seat (#58) to body (#60), with seat gasket (#59).
- B. Lap valve (#57) for SP, SPA, SPD, AF, SS or SSD.
  1. SP, SPA, SPD, & AF – Use Rectorseal® Clover lapping compound or equivalent on valve (#57) & seat (#58). Move valve repeatedly in a Figure 8, and clean compound off valve and seat thoroughly when finished.
  2. SS/SSD – Use 220 & 320 grit silicon sand paper to lap valve & insert (#57). Move valve repeatedly in a Figure 8 on 220 grit paper, then use the 320 grit paper. Wipe valve Rulon insert clean.
- C. Replace plunger cups (#38) in piston (#40) and carefully place into cylinders. SEE PLUNGER CUP KIT for piston repair instructions on page 29.
- D. Main Pivot & Wobble Plate Assembly.
  1. Screw the main pivot assembly (#50) all the way into main pivot bracket assembly (#53) and place pinion (#51) in its slot. For AF/SP/SPA/SPD meters, unscrew the pinion and main pivot bracket assembly 5 full turns. For SS/SSD meters, unscrew the pinion and main pivot bracket assembly 3 ½ full turns. This should help bring meter within range while calibrating.
  2. Drop the slotted screws (#54) into bracket.
  3. Place bracket with screws into main pivot bracket assembly.
  4. Set 5/8" ball bearing (#49) into position.
  5. Place the wear plate (#48) over the screws (#54).
  6. Set wobble plate (#47) onto the screws (#54) and fasten down with lock nuts (#41) & lock washers (#42).
  7. Set slack spring assembly (#45) on wobble plate post, then the Rulon washer (#44) & slack roller (#43).
  8. Mount main pivot bracket assembly to valve (#57) & seat (#58) with lock washers (#42) & screws (#52).
- E. Connect Pistons to Wobble Plate.
  1. Slide piston plunger assembly into each cylinder, careful not to cut or crimp the plunger cup.
  2. Carefully slide connector (#36) over the wobble plate (#47) bearing seats.
  3. Place 1/2" ball bearing (#46) onto wobble plate and cover with bearing seat (#35) & retainer (#33). Tighten bearing seat (#33) with lock washers (#7) and screws (#34).
  4. Rotate wobble plate (#47) & pistons (#40) through each cylinder to make sure of smooth flowing characteristics.

## 682 METER BONNET REPAIR INSTRUCTIONS



### ***!WARNING!***

All internal pressure must be relieved to ZERO (0) pressure before beginning disassembly of meter or components

- I. A. Remove all parts and seals from the meter bonnet and clean them. You may air blast parts with a **glass bead** material to clean parts.
- B. Check for excessive wear or corrosion. NOTE: Problems with any of these following items will require a new bonnet or shafts.
  1. Drive Shaft (#5).
  2. Compensator Shaft (#24).
  3. Bonnet (#12)
    - a. Drive shaft packing surface.
    - b. Compensator shaft surface.
    - c. Counter drive gear assembly seat (#15) & post.
- II. A. Insert drive shaft gear assembly (#18) with Rulon washer (#17) into the meter drive shaft packing. Install drive shaft packing Kit (#9). SEE DRIVE SHAFT PACKING KIT INSTRUCTIONS for more information on page 28.
- B. Slide the counter drive gear assembly (#15) with Rulon washer (#14) over the post. Each meter uses about 3-4 washers (#10) before the cotter pin (#21) is inserted.
- C. Compensator Shaft Assembly
  1. Insert AF/SP/SPA/SPD retaining ring (#16B) or SS/SSD cotter pin (#16A) on to the compensator shaft (#24).
  2. Insert compensator shaft into packing gland.
  3. Install compensator shaft packing kit (#30).  
SEE COMPENSATOR SHAFT PACKING KIT INSTRUCTIONS for more information on page 27.
- D. Mount Bonnet to Base.
  1. Place oring (#13) into housing (#60).
  2. Move compensator shaft (#24) to match pinion (#51) in the base by using the index disc (#27).
  3. Mount bonnet (#12) to base (#60).
  4. Insert screws (#31) and washers (#32), then tighten.

## COMPENSATOR SHAFT SEAL KIT INSTRUCTIONS

1. Remove screws that bolt the meter cover assembly to the meter body. Loosen and remove the entire meter cover assembly.
2. Cut seal wire and remove seal pin from index disc.
3. Unscrew hex nut from the compensator shaft. Remove compensator washer, index disc, index plate and compression spring from the shaft.
4. From inside the cover housing, turn the compensator shaft until the attached truarc "E" retaining ring or cotter pin clears the edge of the counter drive gear. Slide the compensator shaft assembly from the housing.
5. Remove the spacer. Lift the old packing from the housing. Be sure there are no foreign particles left in the cavity and it is without corrosion.
6. Replace the compensator shaft assembly into the cover housing. Support the shaft from beneath while packing the new seal and spacer.
7. Place the packing tool (TCS 600200) over shaft. If you do not have the TCS packing tool, please use masking or other adhesive tape to fully cover the threads on the compensator shaft to protect the seal from being damaged by the sharp threads as the seal is set into place (Figure 1).
8. Lubricate the seal on the inside up and outside oring prior to installation with bearing grease to help the seal slide into the packing cavity. Dynamic seal must have the stainless steel spring in the down position (Figure 2).
9. Remove the packing tool and place spacer over the shaft.
10. Use a long 3/8" socket and a hammer to carefully push seal into packing cavity.
11. Replace the compression spring, index plate, index disc, compensator washer and hex nut to the compensator shaft. Do not fully tighten the hex nut until the meter has been calibrated.
12. Reassemble the meter cover assembly to the meter body assembly and tighten down the screws. Calibrate the meter according to instructions.

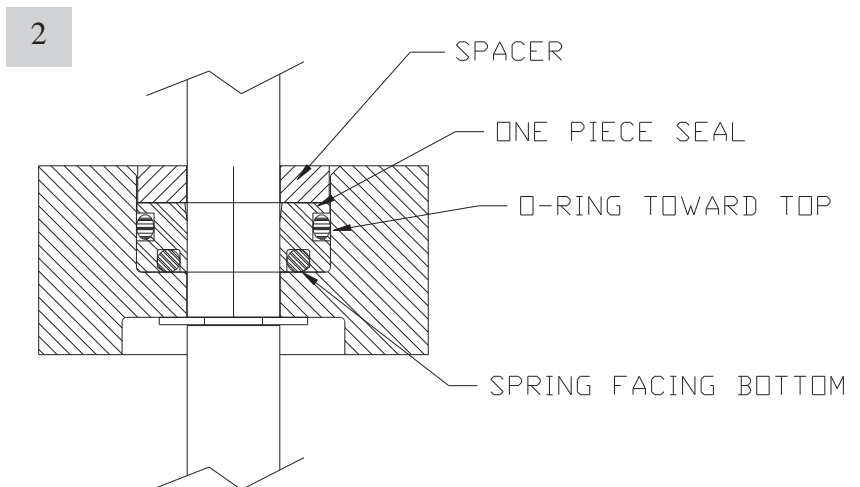

## DRIVE SHAFT SEAL KIT INSTRUCTIONS

1. Remove screws that bolt the meter cover assembly to the meter body. Loosen and remove the entire meter cover assembly.
2. Carefully remove the roll pin from the drive shaft.
3. Remove (3) screws, (3) lock washers, and the compression washer.
4. From inside the cover housing, remove the cotter pin from the counter drive shaft. Remove the counter drive gear and washers. Slide the drive shaft assembly from the housing.
5. Lift the old packing from the housing. Be sure there are no foreign particles or corrosion in the cavity.
6. Replace the drive shaft assembly into the cover housing. Secure in position by reassembling the counter drive gear with the Rulon washers and cotter pin previously removed.
7. Support the counter drive shaft assembly from beneath while packing the spacer bearings, washers and the new seal.
8. Pack first spacer bearing with flat surface on top and push down into packing cavity. Rulon bearing material is preassembled into each spacer bearing. Use caution so as to not damage the surface of the Rulon material (Figure 1).
9. Lubricate the seal inside up and outer oring prior to installation using bearing grease. Place the packing tool (TCS 600100) over shaft to slide the dynamic seal into the packing cavity. Dynamic seal must have the stainless steel spring in the down position (Figure 2).
10. Insert second spacer bearing with flat surface on the bottom.
11. Replace the compression washer with the screws and lock washers.
12. Insert the roll pin in the drive shaft. Be sure to support the shaft while doing this to prevent bending it.
13. Reassemble the meter cover assembly to the meter body assembly and tighten down the screws.

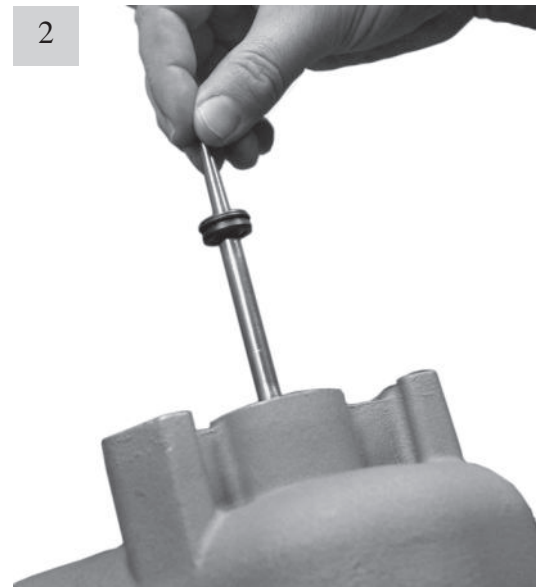
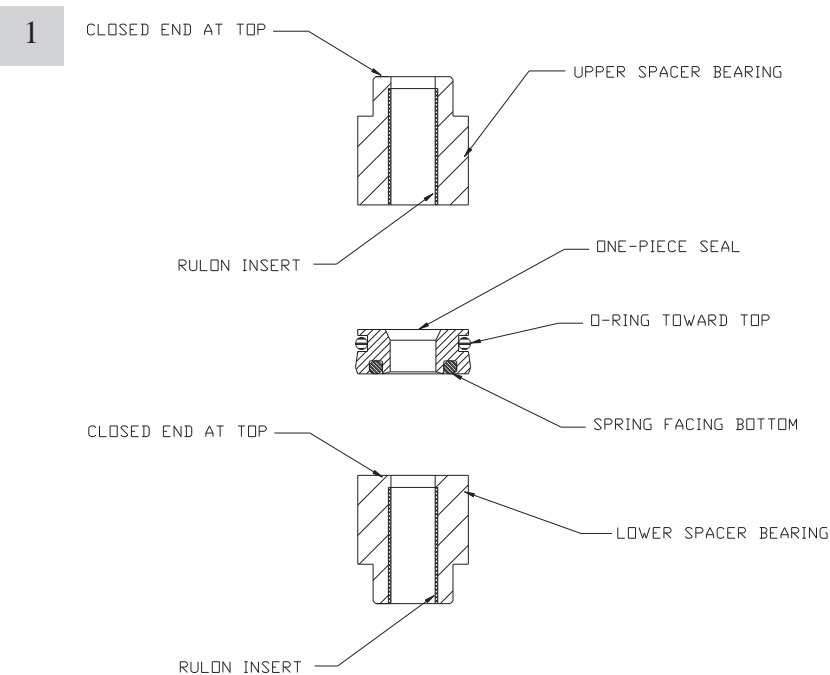

## PLUNGER CUP REPLACEMENT



- 1) Remove plunger assembly from meter body.
- 2) Loosen and remove two (2) round head screws and lift plunger cup support from plunger cup and plunger disc.



- 5) Form the cup by turning the plunger assembly in your hand using your thumb to roll the edge slightly.



- 3) Discard the old plunger cup kit. Place the new plunger cup on the plunger disc.
- 4) Add the cup support and secure with the two (2) round head screws previously removed.

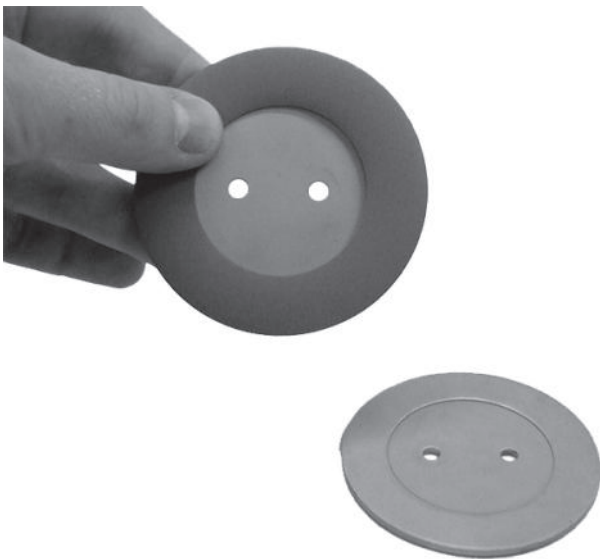

- 6) After the cup is partially formed, place the plunger assembly into the meter body and press into the piston cylinder.



NOTE: Apply Red Loctite 271 (or equivalent) to the screw threads. Be sure the cup is evenly spaced on the plunger disc and support.

- 7) Turn the assembly in the piston cylinder to assure the cup is evenly formed to the cylinder.
- 8) Replace previously removed parts and reassemble meter. Test and calibrate meter for accuracy.



***!WARNING!***

All internal pressure must be relieved to ZERO (0) pressure before beginning disassembly of meter or components

- 1) Using a hex or socket wrench, remove the four screws and washers from the cover plate.
- 2) Remove the cover plate and o-ring from the housing.
- 3) Remove the strainer screen.
- 4) Check inside housing for any debris and remove using a clean cloth.
- 5) Clean strainer screen by rinsing with a liquid cleaning agent compatible to your product application. A brush may be used to remove imbedded particles. If screen is too dirty to clean, then replace the screen.
- 1) Wipe clean the face of the cover plate and seal ring. Check o-rings for damage and replace as needed.

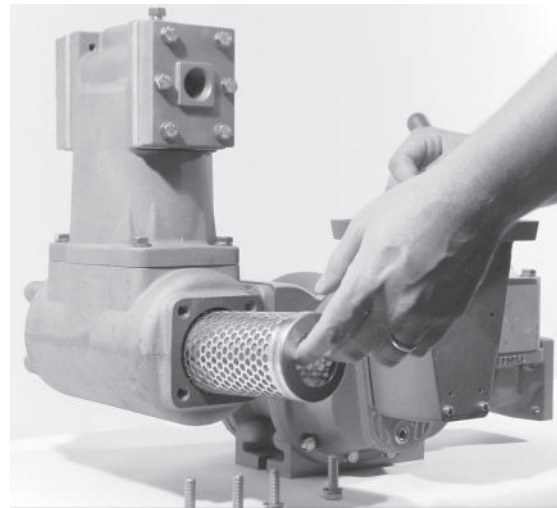
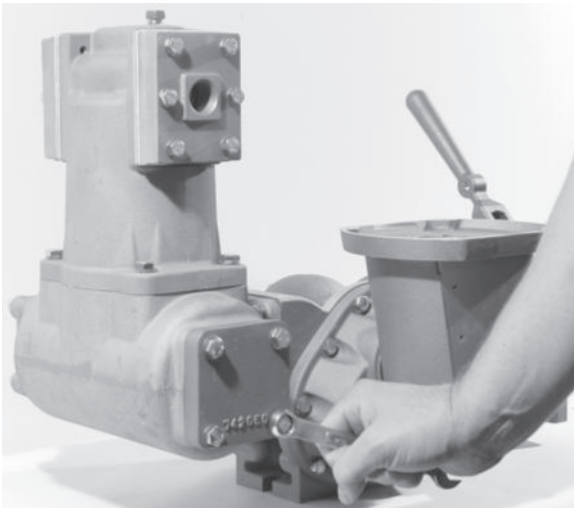

## Reassembly of 720 Strainer Assembly

- 1) Replace the strainer screen into the housing.
- 2) Place the end cover o-ring in the groove of the end cover.
- 3) Put the end cover with o-ring installed on the strainer housing. Replace and fasten end cover with the 4 screws and washers. Tighten the screws according to the torque chart.

***!WARNING!***

All internal pressure must be relieved to ZERO (0) pressure before beginning disassembly of meter or components

- 1) Using a 1/2" wrench or socket, remove the cover screws from air eliminator cover plate.
- 2) Remove cover plate.
- 3) Remove valve plate, inspect and replace as needed.

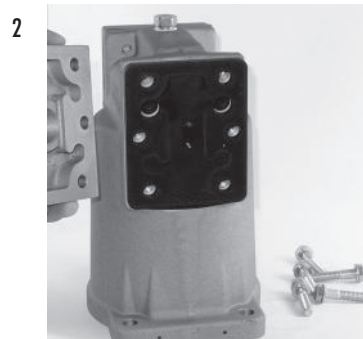
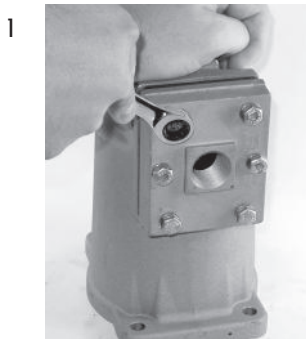

- 1) To remove the air eliminator assembly, remove the four screws and washers attaching it to the strainer assembly.
- 2) Using a flathead screwdriver, remove the screws attaching reed valves to air eliminator housing.
- 3) Remove the two screws on the diffuser screen.
- 4) Slide out diffuser shaft assembly.
- 5) Remove the two screws attaching reed valve to the float assembly. Inspect and replace reed valves as needed.

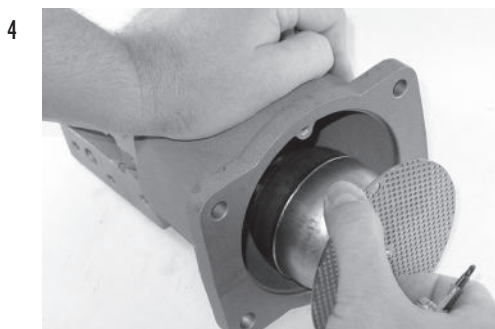
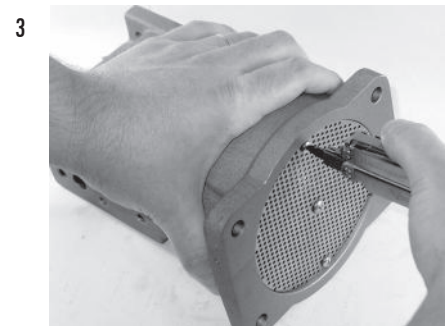
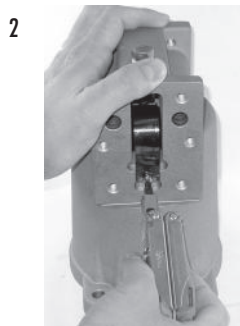
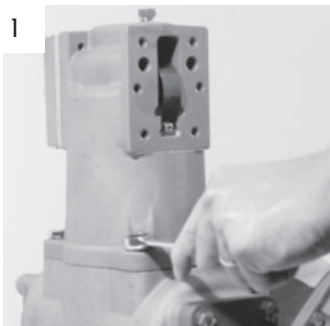

## 650-15 Hydraulic Valve Repair Instructions



### ***!WARNING!***

All internal pressure must be relieved to ZERO (0) pressure before beginning disassembly of meter or components

- 1) Drain all fluid from metering system prior to valve removal.
- 2) Remove the linkage from valve assembly by removing the screws (#18) from the bracket (#17) and lift the arm linkage from the valve assembly.
- 3) Remove valve from meter and piping.
- 4) Remove the roll pin (#21) from the valve stem (#20). Then remove the screws (#26) from the cover (#29) and poppet assembly and lift from the body (#41).
- 5) Inspect the seat of the body (#41) for pitting or foreign matter. Pull the poppet assembly from the cover (#29) and inspect for a damaged plunger cup (#34) and/or valve disc (#36).
- 6) Remove the screws (21) from the poppet guide (#38) to inspect the valve seat (#37) for pitting or excessive wear. Replace as necessary.
- 7) To replace the packing seal (#27) and orings (#28) within the cover (#29), remove the compression washer (#24), screws (#22), washers (#23) and stem (#20) completely.
- 8) Carefully slide packing seal (#27) and orings (#28), then spacer (#25) over valve stem (#20). Reassemble compression washer, screws and washers.

The carbon graphite seals (#27) must be heated and carefully formed by rotating each seal on a smooth 3/8" diameter punch or pencil prior to fitting over the valve stem (#20). Orings (#28) must have the slot facing the fluid for proper installation. CAUTION: Be certain not to damage seals while forming or during insertion into packing cavity. See the illustration below for proper installation sequence.

- 9) Replace the previously removed parts and reassemble the valve.

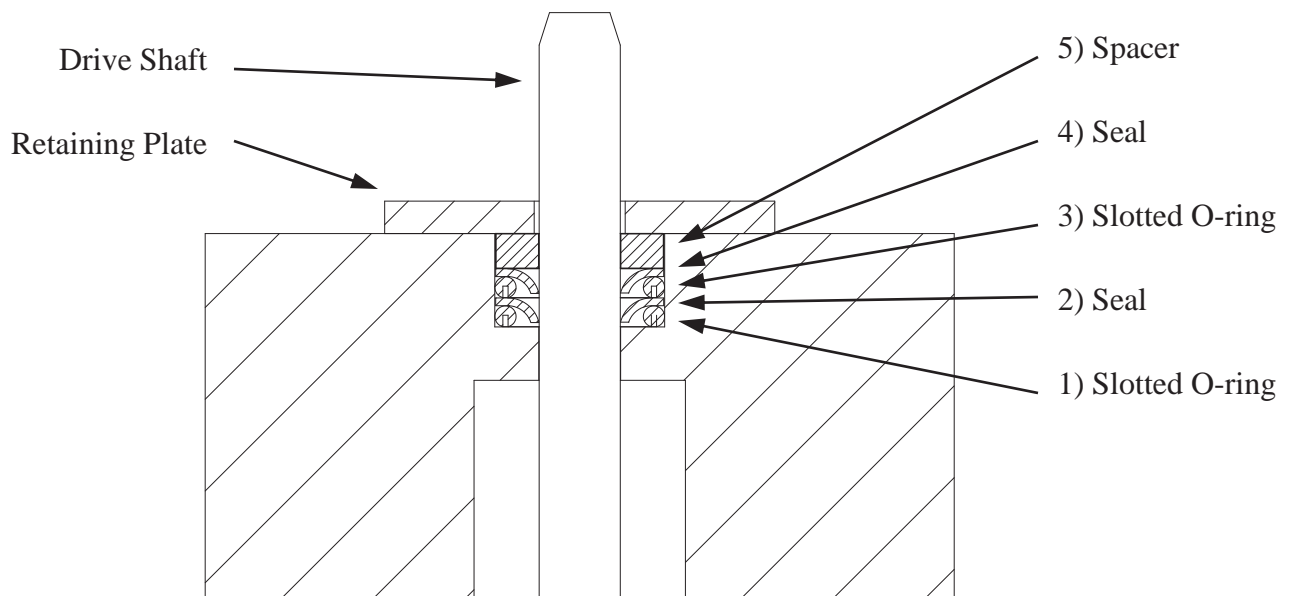



# 650-15 Hydraulic Valve Repair Instructions

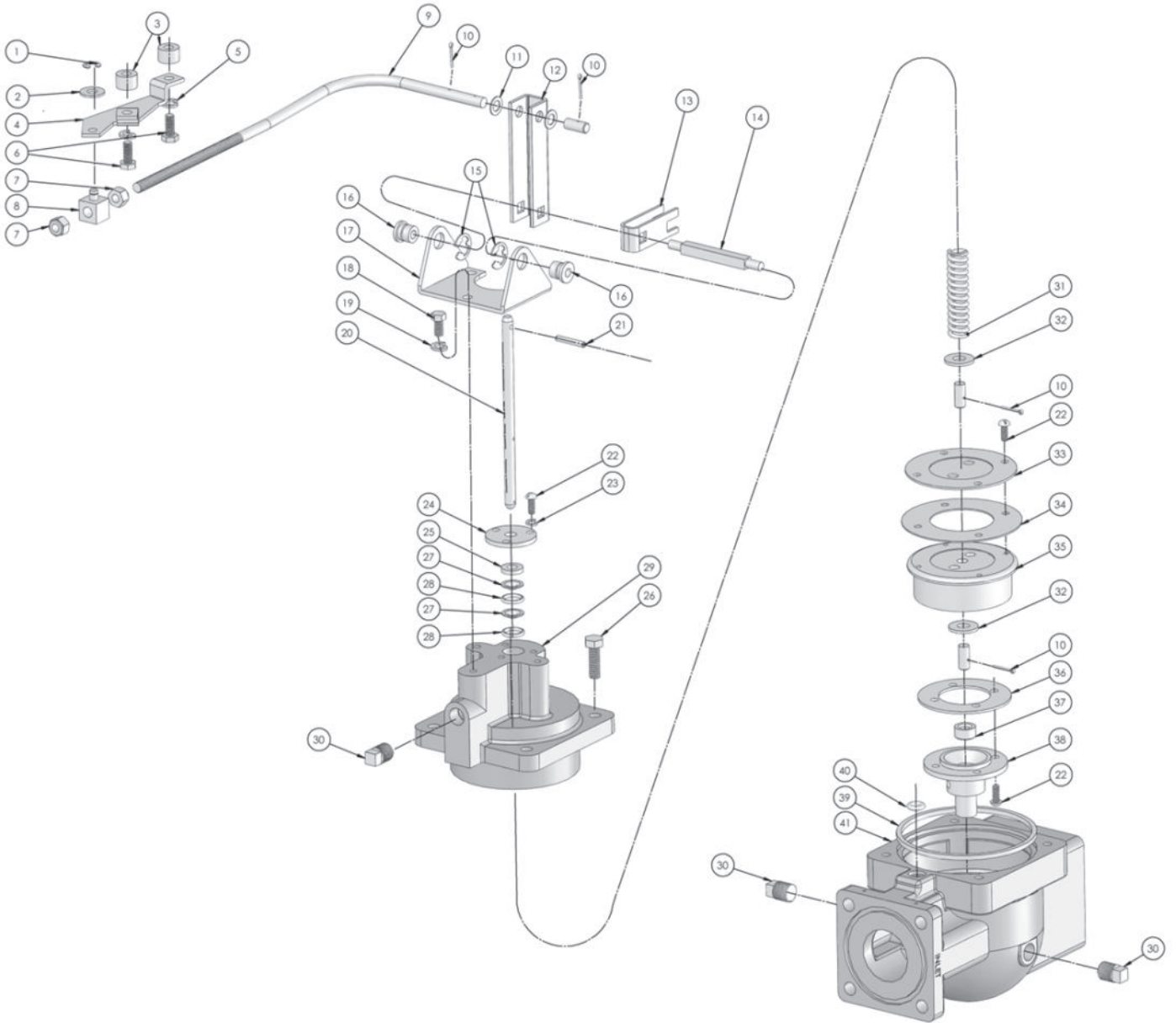

## Meter Trouble Shooting



- A. PROBLEM:** The meter allows product to pass through it, but the register on the meter doesn't move.
- 1) Check the reset knob on the register. On older style Veeder Root registers, this knob can become stuck-in, which will disengage registration. In this case, though, the totalizer would still register.
  - 2) Check the screws that hold the gear plate onto the bottom of the register. If they become loose, neither the register nor the totalizer will register.
  - 3) The drive-gear coupling shaft (in the gear plate under the register) is broken or pin missing.
  - 4) The retaining ring on the counter drive gear has come off or broken, allowing the drive gear to disengage from the drive shaft gear assembly.
  - 5) The post on the wobble plate inside the meter has snapped off. When this happens, it usually indicates that air has been pumped through the meter.
  - 6) The connector on the piston assembly inside the meter is broken, allowing product to pass.
- B. PROBLEM:** The meter will not deliver product and will not register.
- 1) Check any air eliminator and/or strainer screens in the system for blockage. Also, check all valves in the system for proper operation. If the problem still hasn't been discovered after those checks, determine what the pressure is before and after the meter (with the pump running). Equal readings would indicate the meter isn't necessarily the problem.
  - 2) On older style offset Tokheim 682 meters, there is a back pressure valve on the discharge of the meter, which can become stuck shut.
  - 3) If it is determined that the problem is in the meter itself, then the meter valve (inside the meter) is stuck down onto the valve seat.
- C. PROBLEM:** The meter delivers more product than what is registered.
- 1) First, the meter should be tested for repeatability. To test repeatability, run a fast (high gallons per minute) test in your prover and record how much the meter is under registering. Do **NOT** change the meter's calibration. Then, run a slow (low gallons per minute) test and again record the amount that the meter is under registering.
  - 2) If the results from the fast and the slow test are the same or close to the same, the meter has repeatability and can be calibrated. If the test results differ beyond the rated tolerance of the meter, then repairs are necessary.  
NOTE: If the meter is more than 7% inaccurate (register reading of 4.65 or less gallons in a 5 gallon test), then it cannot be calibrated until repairs are made.
- D. PROBLEM:** The meter delivers less product than what it registers.
- 1) The meter could have the wrong gear train in its register.
  - 2) Check for leaks on the suction side of the pump, including the pump seal. Air, which is sucked into the system and pushed through the meter would affect registration.
  - 3) After eliminating these possible causes, check the meter's repeatability, as outlined in problem C above.
  - 4) Register may need repair.
- E. PROBLEM:** The meter has excessive knocking noise.
- 1) Check the calibrator on the meter. If it is adjusted too far out, excessive knocking is possible.
  - 2) If the problem isn't the calibrator, then the meter valve or another internal part may need repair or replacement.

## Air Eliminator Trouble Shooting



A. PROBLEM: Product is flowing from the Air Eliminators vents

- 1) Foreign matter located in between seal plate orings and metal reeds.
- 2) The seal plate oring may be worn through service life.
- 3) The seal plate oring may be cut or dislodged and requires replacement.
- 4) The float may have been punctured, containing liquid, not allowing the float to rise and seal the air vents.
- 5) The float may have been ruptured from a surge of pressure within the system.
- 6) The metal reeds may be fatigued and requires replacement.
- 7) The metal reeds may be out of alignment with the seal plate.

B. PROBLEM: The meter is still registering air within the system

- 1) There can be numerous reasons why the meter may still register air. First look at the system configuration and see where air is being introduced into the system. Then determine if the meter is registering “free air” or “entrained air”. Free Air is much easier to remove from the metering system and may require the use of the Spring Loaded Back Check Valve and/or the Differential Air Check Valve to help the air eliminator operate more effectively. Entrained Air is much more difficult to remove. Typically the best way to eliminate Entrained Air will be to remove the air source of entry into the system. Some examples are from cavitating pumps and leaking pump/valve seals. See Air Elimination in the Service Manual for more information.
- 2) The air return line is not the required minimum of 1/2” ID.
- 3) The metering system has no sufficient way of eliminating the air to atmosphere. Example: Incorrectly installed “Catch Can” reservoir (lower than the air eliminator itself), or the reservoir is allowed to become full, incorrectly sized vent, etc...)

## Preset Valve Trouble Shooting



A. PROBLEM: The valve will not close completely.

- 1) The shaft of the piston may be bent from excessive force.
- 2) Debris may be between the plunger and poppet piston guide.
- 3) The plunger cup seal may be worn, cut or torn.
- 4) The Veeder Root preset may have a worn or bent trip mechanism that is not allowing the preset to function correctly.

B. PROBLEM: The valve shuts immediately upon first stage trip, bypassing the second stage closure.

- 1) The mechanical linkage might need to be adjusted, moving the Nylon locking nuts forward or backwards to change the closing of the preset valve.
- 2) The Veeder Root preset may need to be “raked” or adjusted for the correct shut-off volume. See Veeder Root 7889 preset service manual for further instructions, which may need to be downloaded from the [www.veeder.com](http://www.veeder.com) website.
- 3) The Veeder Root preset may have a worn or bent trip mechanism that is not allowing the preset to function.

C. PROBLEM: The preset batch over or under registers correct volume.

- A) The mechanical linkage might need to be adjusted, moving the Nylon locking nuts forward or backwards to change the closing of the preset valve.
- B) The Veeder Root preset may need to be “raked” or adjusted for the correct shut-off volume. See Veeder Root 7889 preset service manual for further instructions.
- C) The Veeder Root preset may have a worn or bent trip mechanism that is not allowing the preset to function.

# Material Safety Data Sheet

24 HOUR EMERGENCY ASSISTANCE  
(260) 833-3173

GENERAL MSDS ASSISTANCE  
(260) 484-0301

CODE: RPS

HAZARD RATING> LEAST-0 SLIGHT-1 MODERATE-2 HIGH-3 EXTREME-4

DR LUBRICANTS, INC.  
4611 NEWAYGO ROAD, SUITE D  
FORT WAYNE, IN 46808

DATE: 01/21/06  
TELEPHONE NUMBER: (260) 484-0301

## SECTION I - PRODUCT IDENTIFICATION

PRODUCT: **RP 1039**

## SECTION II - COMPOSITION AND HAZARDOUS INFORMATION\*

CHEMICAL NAME	CAS NUMBER	WT. PERCENT IS LESS THAN	OCCUPATIONAL EXPOSURE LIMITS (TLV-TWA) (TLV-STEL)
PETROLEUM HYDROCARBON	64741-65-7	90.0	100MG/M3
PETROLEUM HYDROCARBON	64742-53-6	10.0	5MG/M3

\*ITEMS NOT SHOWN ARE NOT LISTED IN THE OSHA - T.S.C.A. HAZARDOUS CHEMICALS LISTING.

## SECTION III - PHYSICAL DATA

BOILING RANGE:	NA	VAPOR DENSITY:	NA
ODOR:	PETROLEUM ODOR	EVAPORATION RATE:	NA
APPEARANCE	AMBER LIQUID	SOLUBILITY:	INSOLUBLE
VOLATILE BY WEIGHT:	NA	PRODUCT DENSITY:	0.790
VOLATILE BY VOLUME:	NA		

## SECTION IV - FIRE AND EXPLOSION HAZARD DATA

FLAMMABILITY CLASSIFICATION:	COMBUSTIBLE	FLASH POINT: 150 F (CLEVELAND OPEN CUP)	LEL: NA UEL: NA
DOT:	COMBUSTIBLE LIQUID		
EXTINGUISHING MEDIA:	CARBON DIOXIDE, DRY CHEMICAL, FOAM		

# Material Safety Data Sheet (Continued)

PRODUCT: RP 1039  
PAGE - 2

=====

## SECTION IV - FIRE AND EXPLOSION HAZARD DATA

=====

UNUSUAL FIRE AND EXPLOSION HAZARDS : DO NOT DIRECT A SOLID STREAM OF WATER ONTO BURNING PRODUCT. THIS MAY CAUSE SPREADING AND INCREASE THE FIRES INTENSITY. COMBUSTION MAY PRODUCE: OXIDES OF CARBON, AND INCOMPLETELY BURNED HYDROCARBONS IN THE FORM OF FUMES AND SMOKE.

SPECIAL FIREFIGHTING PROCEDURES: WEAR A SELF-CONTAINED BREATHING APPARATUS WITH FULL FACEPIECE.

=====

## SECTION V - HEALTH HAZARD DATA

=====

EFFECTS OF OVER EXPOSURE: MAY CAUSE MILD EYE IRRITATION AND REDNESS. PROLONGED OR REPEATED EXPOSURE TO THE SKIN MAY RESULT IN LOSS OF NATURAL OILS ACCOMPANIED BY DRYNESS, CRACKING AND DERMATITIS. INGESTION MAY RESULT IN NAUSEA, DIARRHEA AND GASTRO INTESTINAL IRRITATION. OVEREXPOSURE TO MIST MAY CAUSE UPPER RESPIRATORY TRACT IRRITATION AND DIFFICULTY BREATHING.

MEDICAL CONDITIONS PRONE TO AGGRAVATION BY EXPOSURE: NONE KNOWN.

PRIMARY ROUTE(S) OF ENTRY: DERMAL INHALATION INGESTION.

EMERGENCY AND FIRST AID PROCEDURES: IN CASE OF EYE CONTACT, IMMEDIATELY FLUSH EYES WITH CLEAN WATER FOR AT LEAST 15 MINUTES. IF EYE IRRITATION PERSISTS, CONTACT A PHYSICIAN. IN CASE OF SKIN CONTACT, REMOVE ANY CONTAMINATED CLOTHING AND RINSE SKIN THOROUGHLY WITH WATER FOR AT LEAST 15 MINUTES. IF SKIN IRRITATION PERSISTS, CONTACT A PHYSICIAN. IN CASE OF OVEREXPOSURE TO MIST, REMOVE VICTIM TO FRESH AIR: IF BREATHING IS DIFFICULT ADMINISTER OXYGEN: AND CONTACT A PHYSICIAN IMMEDIATELY. IF PRODUCT IS INGESTED DO NOT INDUCE VOMITING: CONTACT A PHYSICIAN.

=====

## SECTION VI - REACTIVITY DATA

=====

STABILITY: THIS PRODUCT IS STABLE UNDER NORMAL STORAGE CONDITIONS.

HAZARDOUS POLYMERIZATION: WILL NOT OCCUR UNDER NORMAL CONDITIONS.

HAZARDOUS DECOMPOSITION PRODUCTS: THERMAL DECOMPOSITION MAY RESULT IN THE FORMATION OF: OXIDES OF CARBON, AND INCOMPLETELY BURNED HYDROCARBONS IN THE FORM OF FUMES AND SMOKE.

CONDITIONS TO AVOID: AVOID CONTACT WITH OPEN FLAME, STORE IN ROOM TEMPERATURE AREA.

---

# Material Safety Data Sheet (Continued)

PRODUCT: RP 1039  
PAGE - 3

INCOMPATIBILITY: AVOID CONTACT WITH STRONG OXIDIZING AND REDUCING AGENTS AND STRONG ALKLI.

=====

## SECTION VII - SPILL OR LEAK PROCEDURES

=====

STEPS TO BE TAKEN IN CASE MATERIAL IS RELEASED OR SPILLED: FOR SMALL SPILLS: SOAK UP SPILL WITH ABSORBENT MATERIAL. FOR LARGE SPILLS: DIKE SPILL AND PUMP INTO DRUMS FOR PROPER DISPOSAL.

WASTE DISPOSAL METHOD: DISPOSE OF IN ACCORDANCE WITH ALL LOCAL STATE AND FEDERAL REGULATIONS.

=====

## SECTION VIII - SAFE HANDLING AND USE INFORMATION

=====

RESPIRATORY PROTECTION: NORMALLY NOT REQUIRED, HOWEVER, WHEN THE TLV IS EXCEEDED WEAR THE APPROPRIATE MSHA/NIOSH APPROVED RESPIRATOR.

VENTILATION: PROVIDE ADEQUATE VENTILATION (SUCH AS MECHANICAL OR LOCAL) TO ASSURE TLV IS NOT EXCEEDED.

PROTECTIVE GLOVES: NORMALLY NOT REQUIRED, HOWEVER, IF HANDS ARE FREQUENTLY IN FLUID WEAR OIL AND CHEMICAL IMPERVIOUS GLOVES.

EYE PROTECTION: SAFETY GLASSES REQUIRED FOR NORMAL USAGE, WEAR CHEMICAL GOGGLES WHEN EXCESSIVE SPLASHING MAY OCCUR.

OTHER PROTECTIVE EQUIPMENT: NORMALLY NOT REQUIRED, HOWEVER, WHERE REPEATED CONTACT OCCURS, WEAR IMPERVIOUS CLOTHING AND BOOTS.

HYGIENIC PRACTICES: FOLLOW STANDARD INDUSTRIAL HYGIENE PRACTICES. LAUNDER ANY CONTAMINATED CLOTHING BEFORE RE-USE.

=====

## SECTION IX - SPECIAL PRECAUTIONS

=====

PRECAUTIONS TO BE TAKEN IN HANDLING AND STORAGE: DO NOT STORE IN THE PRESENCE OF HEAT, SPARKS, FLAME OR ANY OTHER SOURCES OF IGNITION. STORE AWAY FROM STRONG OXIDIZING AGENTS. EMPTY DRUMS MAY CONTAIN PRODUCT RESIDUES. ALL SAFETY PRECAUTIONS TAKEN WHEN HANDLING THIS PRODUCT SHOULD ALSO BE TAKEN WHEN HANDLING EMPTY DRUMS AND CONTAINERS.

OTHER PRECAUTIONS: NONE

# Material Safety Data Sheet (Continued)

PRODUCT: RP 1039  
PAGE - 4

=====

SECTION X - HMIS/NFPA RATINGS

=====

HMIS:HEALTH:1 FLAMMABILITY:2 REACTIVITY:0 PERSONAL PROTECTION:C  
NFPA:HEALTH:1 FLAMMABILITY:2 REACTIVITY:0 SPECIFIC HAZARD:

=====

SECTION XI - OTHER REGULATORY INFORMATION

=====

DOT HAZARDOUS:      NATURAL DESCRIPTION:

=====

THE INFORMATION CONTAINED HEREIN IS, TO THE BEST OF OUR KNOWLEDGE AND BELIEF, ACCURATE. HOWEVER, SINCE THE CONDITIONS OF HANDLING AND USE ARE BEYOND OUR CONTROL, WE MAKE NO GUARANTEE OF RESULTS, AND ASSUME NO LIABILITY FOR DAMAGES INCURRED BY USE OF THIS MATERIAL. IT IS THE RESPONSIBILITY OF THE USER TO COMPLY WITH ALL APPLICABLE FEDERAL, STATE AND LOCAL LAWS AND REGULATIONS.

=====



## Notes

## Notes

## **Warranty Information**

### **WARRANTY**

New 682 piston meters manufactured by Total Control Systems, a division of Murray Equipment, Inc. ("TCS") with which this warranty is enclosed, are warranted by TCS to the original purchaser only for a period of ten (10) years from the date of shipment, to be free, under normal use and service, from defects in material and workmanship. TCS manufactured new equipment or components are warranted for a period of one (1) year from the date of shipment, under normal use and service. This warranty is extended only to the original purchaser. For defects occurring within the stated warranty period, TCS will repair or replace, at TCS's option; provided that part or parts are returned to TCS transportation charges prepaid, and the TCS's examination discloses the parts or workmanship to have been defective upon delivery to the purchaser.

### **EXCLUSIONS**

TCS's ten (10) year warranty applies to meters only and does not apply to accessories such as valves and air eliminators. Parts and equipment not manufactured by TCS may be covered by separate warranties of their respective manufacturers. This warranty does not cover any parts or equipment not manufactured by TCS or related companies. This warranty does not extend to any equipment that has been altered in any way, subjected to misuse, negligence, accident, or if operated in any manner other than in accordance with TCS's operating instructions or have been operated under conditions more severe than, or otherwise exceeding those set forth in the specifications. General maintenance, calibration, clean up and normal wear is excluded from this limited warranty.

### **CLAIM PROCEDURES**

In order to obtain performance by TCS of its obligations under this warranty, the original purchaser must obtain a Return Goods Authorization (RGA) number from TCS's customer service department within 30 days of discovery of a purported breach of warranty, but not later than the expiration of the warranty period. Once authorization is received, return the defective meter, piece of equipment, or component covered by this warranty, with transportation charges prepaid, to TCS with a written statement setting forth the nature of the defect and RGA number.

### **LIMITATIONS**

THERE ARE NO OTHER WARRANTIES OF ANY KIND, EXPRESS OR IMPLIED. TCS SPECIFICALLY DISCLAIMS ANY WARRANTY OF MERCHANTABILITY OR OF FITNESS FOR ANY PARTICULAR PURPOSE. TCS will determine if all parts or meter defect falls within the warranty guidelines and will repair or replace within a reasonable time span. TCS is not responsible for any in or out bound freight. TCS's sole obligation that shall represent the buyer's sole and exclusive remedy shall be to repair or at TCS's option to replace any product or part determined to be defective. In no event shall TCS be liable for any special, direct, indirect, incident, consequential or other damages of similar nature, including without limitation, loss of profits, products, production time, or loss of expenses of any nature incurred by the buyer or any third party. TCS has not authorized on its behalf any representation or warranties to be made, nor any liability to be assumed except as expressly provided herein; there is no other express or implied warranty.

### **REPAIR WARRANTY**

All repair work is warranted for (90) days from the date of shipment to customer. Some parts may be warranted for longer periods by the Original Equipment Manufacturer.

### **DESIGN AND EQUIPMENT CHANGES**

Any changes in design or improvements added shall not create any obligation to install or replace equipment previously sold or ordered.

**TOTAL  
CONTROL  
TCS SYSTEMS**

*"The Standard of Measurement"*

2515 Charleston Place  
Fort Wayne, IN 46808

Toll Free: (800) 348-4753  
Phone: (260) 484-0382  
Fax: (260) 484-9230  
Email: [sales@tcsimeters.com](mailto:sales@tcsimeters.com)